

CATALOGO GENERALE
PRODUCTS CATALOGUE



2017/2018



Indice *Index*

Delfin: la storia / <i>the story</i>	5-9	BENNE ASPIRANTI/ VACUUMING SEPARATORS	
Informazioni tecniche / <i>technical info</i>	9	B200 M - C600 M	38
MISTRAL		C600T75 - C600T125	39
301 Dry	12	TECNOIL	
501WD-802WD	13	Tecnoil 100 IF	40-41
202 DS	14-15	Tecnoil 200	42
352 DS	16-17	Tecnoil 400 - 600	43
3533-3535	18	AIR	
Pharma 20-30	19	Air 501 WD -Air 802 WD	44-45
DM		Air 202 DS -Air 352 WD	46-47
DM 3	20-21	Air DM 3- Air HD 200	48-49
DM 40 OIL	22	ATEX - AIREX	50-53
DM 40 WD / DM 40 SGA	23	DIRECT X	
DM ENTRY LEVEL		OEM	54-59
DM 3 EL	24	LABCONTROL	
DM 2 EL / DM 3 EL LP	25	LC1000D-LC1100WD-LC1100DS	60-61
ZEFIRO		AIRFLOW	
Zefiro EL M/T	26	Depolveratori / <i>Dedusters</i>	62-63
Zefiro 75	27	Fumi di saldatura / <i>Welding fumes</i>	64-65
DG EXP		SEPARATORI / SEPARATORS	66-67
DG EXP 30-50-70	28-29	Accessori / <i>Accessories</i>	68-69
DG 75 / DG 75 AF	30-31	CVS	
DG VL		Impianti centralizzati / <i>centralized systems</i>	70-73
DG VL 75-110	32	DHV	
DG VL 125-185	33	Unità alto vuoto / <i>High vacuum units</i>	74
DG HD		Referenze / <i>References</i>	75
DG HD 200-300	34-35		
Opzioni / <i>Options</i>	36-37		





Qualità. Design. Innovazione. Da oltre venticinque anni.

Delfin nasce oltre venticinque anni fa dalla passione del suo fondatore, Antonino Siclari, per il settore dell'aspirazione industriale. Da allora non ha mai smesso di lavorare per proporre ai propri clienti soluzioni innovative ed efficienti, ai vertici per qualità e design. Oggi risolve i problemi di aspirazione per professionisti e industrie in tutto il mondo.

Forte di scelte imprenditoriali innovative e coraggiose, l'azienda è l'unica realtà industriale capace di fornire un servizio veramente a 360 gradi nel campo dell'aspirazione industriale. Grazie ad una gamma che vanta più di 100 modelli si pone come interlocutore unico per ogni necessità, garantendo la giusta soluzione in ogni settore applicativo.

Dal 2009 opera direttamente sul mercato tedesco con una filiale di proprietà, la **Delfin Deutschland Industriesauger GmbH**.

Nel 2013 Delfin ha inaugurato una nuova filiale, **Delfin Asia Pacific**, in Vietnam ad Ho Chi Minh, al fine di fornire un miglior servizio distributivo in tutto il sud est-asiatico e Oceania.

Quality. Design. Innovations. For more than twenty five years.

Delfin was created over twenty five years ago by the passion of its founder, Antonino Siclari, for the field of industrial vacuum. Since then it has never stopped working to offer innovative and efficient solutions to its customers. Today Delfin provides state of the art industrial vacuum solutions to professionals and industries around the world.

Thanks to its innovative and entrepreneurial choices, the company represents the only industrial partner capable of providing a truly 360 degrees know-how in the field of industrial vacuums. With a range composed of more than 100 models, Delfin is always able to ensure the right solution in each application area.

*Since 2009, it operates directly on the German market with a wholly owned branch, **Delfin Deutschland Industriesauger GmbH**.*

*In 2013 Delfin opened a new branch, **Delfin Asia - Pacific**, in Vietnam in Ho Chi Minh City, in order to ensure a better distribution service across the South - East Asia and Oceania.*

Soluzioni per migliorare l'efficienza.

Gli aspiratori industriali Delfin non sono semplici aspirapolvere ma strumenti capaci di aumentare l'efficienza di ogni ciclo produttivo industriale, garantendo gli standard di sicurezza e pulizia anche negli ambienti più esigenti. Dal laboratorio farmaceutico alla fonderia, dal piccolo panificio alla grande industria dell'automotive, i nostri aspiratori hanno risolto e continuano a risolvere le necessità di aspirazione in tutto il mondo.

6

L'affidabilità. Oltre ogni limite.

Scopri ogni giorno l'affidabilità delle macchine Delfin. Non solo perchè ogni aspiratore è la sintesi perfetta di qualità, sicurezza e tecnologia, ma perchè hai a tua disposizione un servizio unico, attento alle tue esigenze e ai tuoi bisogni.

Inoltre Delfin ti offre di più, in termini di garanzia, andando oltre quanto previsto dalla legge. Ogni aspiratore, infatti, gode di ben **2 anni di Garanzia** nel caso in cui siano presenti anomalie di costruzione. Tutte le macchine Delfin sono marcate CE e sono assemblate attraverso un processo certificato per la qualità ISO 9001. Inoltre la maggior parte è disponibile con certificazione ATEX.

Solutions that improve efficiency.

Delfin's industrial vacuum cleaners are not simple vacuum cleaners but true industrial tools capable of increasing the efficiency of each industrial process, ensuring security and cleaning standards even in the most demanding environments. From the pharmaceutical laboratory to the foundry, from the small bakery to the largest automotive industry, our vacuum cleaners have solved and continue to satisfy the cleaning requirements of industries worldwide.

Reliability. Beyond all limits.

Discover every day the reliability of each Delfin machines. Not only because each vacuum cleaner is the perfect combination of quality, safety and technology, but also because you have at your disposal a Unique service, attentive to your requirements and your needs.

*Moreover Delfin gives you more going beyond what is required by law. Each industrial vacuum cleaner, in fact, has no less than **2 years of warranty** in the remote case in which there are abnormalities of construction. All of Delfin's machines are CE marked and are assembled through a quality certified process to the ISO 9001 standard. Furthermore, the majority is available with ATEX certification.*

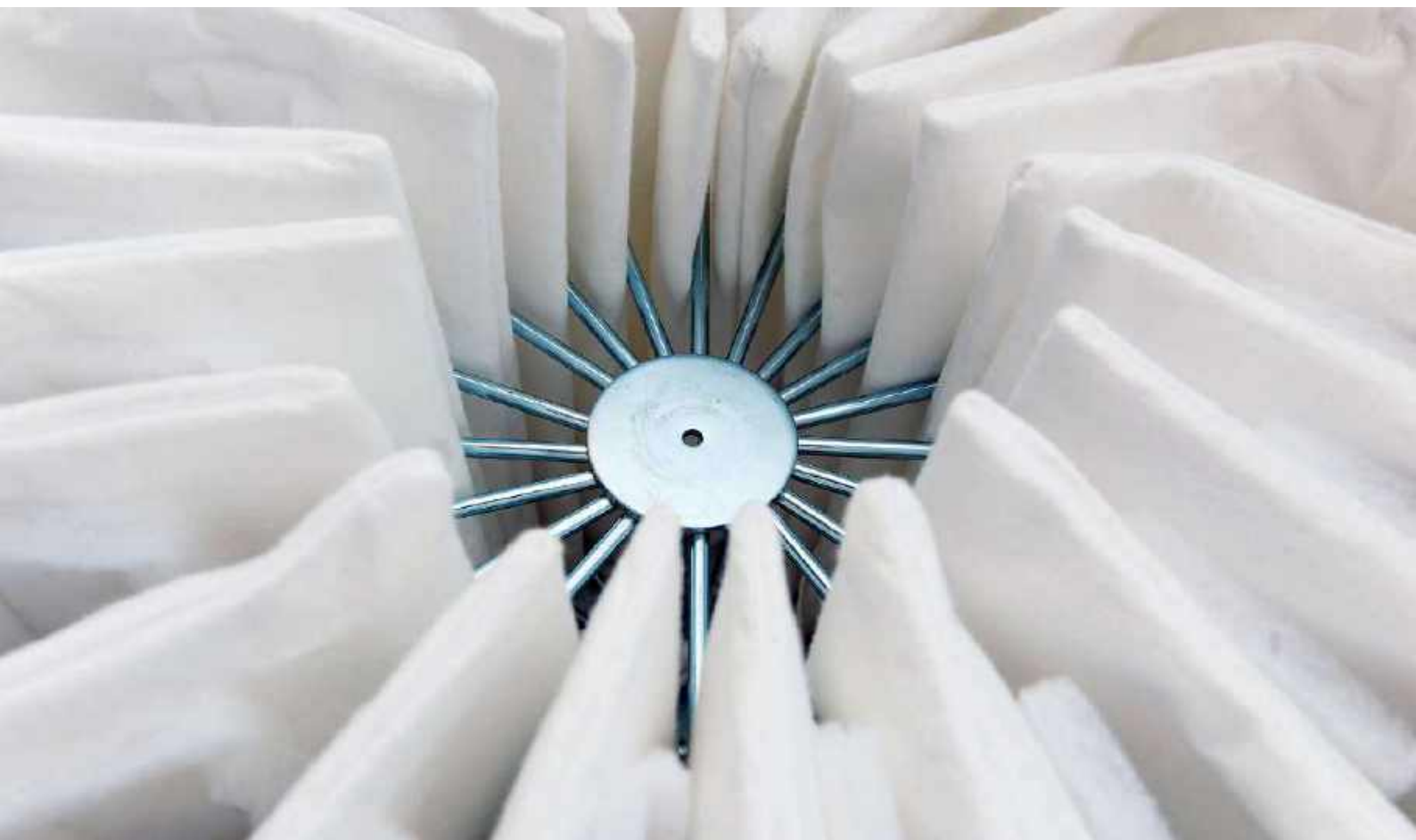



Ricambi originali. Perché nessuno conosce Delfin meglio di Delfin.

Turbine da 1,8 a 25 kW, ricambi per ogni singolo modello, tubi di ogni diametro e lunghezza, tempi di spedizioni ridotti all'osso. Questi sono solo alcuni dei vantaggi di un magazzino di quasi 5.000 mq, che in meno di 48 h dalla data dell'ordine, può farvi avere il materiale di cui avete bisogno. I Ricambi Ufficiali Delfin consentono di mantenere nel tempo il valore e l'efficienza della macchina per cui sono stati appositamente progettati e fanno sì che un aspiratore Delfin sia sempre un Delfin.

Accessori originali Delfin. Unici come il tuo lavoro.

Un aspiratore Delfin può essere configurato e reso davvero unico, perfettamente adatto al tuo lavoro. Progettati specificamente per valorizzare la funzionalità di ogni modello, gli accessori originali sanno senza dubbio accrescere il comfort e l'efficienza di utilizzo di un aspiratore Delfin.

Original spare parts. Because no one knows Delfin better than Delfin.

Side channel blowers from 1 to 25 kW , spare parts for each single model , hoses of all diameters and length, timing of shipments cut to the bone . These are just some of the advantages of a warehouse of nearly 5,000 square meters, which in less than 48 hours from the order date can ship the material that you need. Delfin's Original Spare Parts allow each vacuum to maintain its value and efficiency of the machine for which they were specially designed over time, while guaranteeing that a Delfin vacuum is always a Delfin.

Original accessories. As unique as your business.

Each Delfin vacuum cleaner can be configured and made unique, perfectly suited to your work. Designed specifically to enhance the functionality of each model, original accessories will without any doubt enhance the comfort and the efficiency of use of any Delfin vacuum cleaner.

L'eccellenza Made in Italy.

Qualità assoluta. Vita decennale. Efficienza continua. Questo risultato è reso possibile grazie a costanti investimenti in R&D ed al dialogo diretto e costruttivo con i clienti. Il dipartimento di ricerca&sviluppo, oltre a garantire la costante evoluzione del prodotto, permette anche la personalizzazione e la realizzazione di esecuzioni speciali, specificamente progettate sulle esigenze dei clienti.

L'eccellenza non è una parola è uno stile di vita. Con questa idea sempre in mente i nostri esperti collaboratori assemblano, testano e verificano il corretto funzionamento di ogni minima parte dei nostri prodotti, dalla prima all'ultima macchina. Perché la qualità per Delfin non è una promessa, ma una certezza. Ogni aspiratore Delfin è costruito in Italia, con componenti Made in Italy attraverso un processo produttivo certificato per la qualità DNV ISO 9001.

8

Made in Italy Excellence.

Absolute quality. Almost infinite life. Continuous Efficiency. This result is made possible thanks to constant investment in R & D and to direct and constructive dialogue with the customers. Our department of Research & Development, as well as ensuring the never ending development of the product, empowers the customization of machines and the creation of special designs, specifically designed on the customers' needs.

Excellence is not a word, it is a lifestyle. With this idea in mind our expert staff assemble, test and verify the correct operation of each small part of our industrial vacuums, from the first to the last machine. Delfin quality is not a promise, but a certainty. Each Delfin vacuum cleaner is built in Italy, with components Made in Italy or in Germany, through a process of production which has been certificated for quality by DNV with the ISO 9001.

DELFIN WORLD WIDE

I nostri impianti di produzione si trovano a Settimo Torinese, alle porte di Torino (Italia). Operiamo in tutto il mondo attraverso filiali dirette e distributori ufficiali.

Our production facilities are located in Settimo Torinese, near Turin (Italy). We operate worldwide through direct branches and official distributors.





Visita il sito web!

Tutte le schede tecniche, le foto delle applicazioni e i video di presentazione prodotti a portata di click!

Smartphone, Tablet, Pc, scegli tu!

Tutti i canali web Delfin sono stati disegnati per essere totalmente responsivi. Ciò significa massima facilità di navigazione del sito da qualunque strumento, per una consultazione rapida ed efficace.

Visit the website!

All the data sheets, application photos and videos at your total disposal!

Smartphone, Tablet, PC, you choose!

All of Delfin's web channels have been designed to be fully responsive. This means ease of navigation on the site by any mobile device, for a quick and effective browsing.

www.delfinvacuums.it



Facebook



Youtube



Linkedin

Seguici!

Follow Us!



Un dubbio, una domanda, una richiesta? Nessun problema!

Il servizio che Delfin riserva ai propri clienti non si limita ai tradizionali mezzi di comunicazione. Il nostro team di **Customer Service** infatti è sempre disponibile a rispondere alle tue domande sulla nostra chat sul sito **delfinvacuums.it**, così come su tutti i nostri canali social. Prova, è facile e immediato!

A doubt, a question, an inquiry? No problem!

The service Delfin offers to its customers is not limited to traditional media. Our Customer Service team is always available to answer your questions on our chat on delfinvacuums.it as well as on all our social channels. Test it, it is quick and easy!

Applicazioni Applications



Materie Plastiche
Plastic Industry



Vetro
Glass Industry



Carta
Paper Industry



Legno
Wood Industry



Alimentare
Food Industry



Farmaceutico
Pharmaceutical Industry



Chimico/Petrochimico
Chemical, Oil & Gas Industry



Edilizia / Trattamento Superfici /Cantieri
Construction / Surface Preparation



Metallurgia / Fonderia / Cementifici /
Ceramica - *Metal Working / Foundries /
Cement / Ceramics*



OEM (Asp. a bordo macchina)
OEM (Fixed Vacuum Units)



Trattamento Rifiuti
Waste Management / Recycling



Pulizia Veicoli
*Car Wash / Vehicles Cleaning and
Maintenance*



Militare
Military



Navale / Cantieri Navali
Marine / Shipyards



Meccanica
Engineering / Mechanics

Opzioni Options



Filtrazione a cartuccia con pulizia in
controcorrente d'aria alternata.
*Automatic reverse pulse filter cleaning
system*



Extra Large Filter, superficie
di filtrazione maggiorata.
*ELF Extra Large Filter, enlarged filtration
surface.*



Scuotifiltro automatico temporizzato.
Automatic Filter cleaning system.



Filtro in categoria H per polveri fini
o tossiche (efficienza 99,995% fino
0,18 μ).
*Class H Filter for fine or toxic dust
(efficiency 99,995% - 0,18 μ).*



Filtro in categoria M (efficienza $\geq 1\mu$).
Class M Filter (efficiency $\geq 1\mu$)



Longopac® System



Antistatico/Messa a terra
Antistatic/Grounding



Nomex, filtro resistente alle alte
temperature fino a 250°
*Nomex filter, resistant to high
temperatures up to 250°*



Versione Atex disponibile
Atex Version Available



Galleggiante per protezione motore
per liquidi.
*Floating device for motor protection
from liquids.*



Ruote Toolman, pneumatici per off
road
*Toolman wheels, tires for uneven
surfaces*



Acciaio Inox
Stainless Steel



Politetrafluoroetilene, rivestimento
per facilitare il distacco di materiali
umidi, schiumosi o fangosi dal filtro.
*Polytetrafluoroethylene, film cover that
facilitate the detachment of wet, foamy
or muddy materials from the filter.*

La vostra sicurezza, la nostra priorità!

Your safety, our priority!

La sicurezza non è solo un concetto astratto, ma una vera e propria filosofia in Delfin. Dalla progettazione alla certificazione, il nostro obiettivo è di fornire ai nostri clienti aspiratori industriali al top per qualità, sicurezza e funzionalità.

Safety is not just an abstract concept but a real philosophy at Delfin. From engineering to certification, our goal is to provide to our customers state of the art, safe, user-friendly extraction solutions.

	Zone Zone	Periodo di tempo durante il quale persiste un'atmosfera esplosiva Duration of occurrence of an explosive atmosphere	Categoria attrezzature Equipment category
Gas, nebbie o vapori <i>Gases, mists or steam</i>	0	Permanenti, frequenti, per lunghi periodi di tempo <i>Continuously, for a long period, frequently</i>	1G
	1	Occasionalmente <i>Occasionally</i>	2G
	2	Raramente o per brevi periodi <i>Rarerly or for short period</i>	3G
Polveri <i>Dusts</i>	20	Permanenti, frequenti, per lunghi periodi di tempo <i>Continuously, for a long period, frequently</i>	1D
	21	Occasionalmente <i>Occasionally</i>	2D
	22	Raramente o per brevi periodi <i>Rarerly or for short period</i>	3D

11

Classificazione delle polveri Dust Category

Classificazione secondo normativa DIN EN 60335-2-69, Appendice AA.

Classificazione delle polveri Dust class	Classe filtri Filter Class	Permeabilità massima Maximum permeability
L rischio limitato <i>low risk</i>	L	< 1%
M rischio medio <i>medium risk</i>	M	< 0,1%
H rischio alto <i>high risk</i>	H	< 0,005%



Mistral

Aspiratori Compatti
Compact Vacuum Cleaner

MISTRAL/ 301 DRY DUSTOP



MTL301 disponibile con
certificazione TÜV SUD
MTL301 available with
TÜV SUD certification



12



1 potente motore by-pass Lamb
Ametek
1 powerful Lamb-Ametek by-pass
motor



Filtro da 1m² certificato cat. M
1m² filter class M certified



Contenitore a sgancio per svuotamento rapido
Detachable container for fast discharge

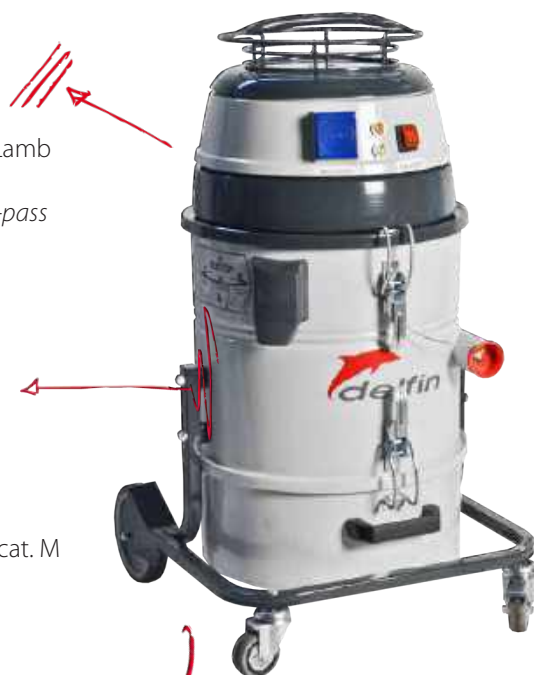

L'aspiratore più compatto della gamma Delfin

- aspirazione generata da un potente motore monofase
- estrema sicurezza garantita dal filtro industriale di grande superficie
- sistema DUSTOP per la pulizia del filtro tramite pressione differenziale
- possibilità di utilizzo per il recupero di polvere da elettrodomestici grazie all'opzione di marcia/arresto automatica
- molteplici configurazioni possibili: filtro HEPA, costruzione INOX, filtro NOMEK, ecc.

Delfin's most compact dust extractor

- suction generated by a powerful single phase motor
- extreme safety offered by a large surface industrial filter
- DUSTOP filter cleaning system using pressure differential
- possibility to recover of dust from power tools thanks to the automatic start / stop option
- many possible configurations: HEPA filter, stainless steel construction, NOMEK filter, etc.

301 DRY DUSTOP

Tensione / Voltage	V	230 1~
Frequenza / Frequency	Hz	50
Potenza / Power	kW	1,15
Depressione / Water Lift	mmH2O	2500
Portata d'aria / Air flow max.	m ³ /h	180
Superficie filtrante / Filter surface	cm ²	6.000
Categoria filtro / Filter Class	(IEC 60335-2-69) optional	M
Sup. filtro HEPA / HEPA-Filter Surface	cm ²	25.000
Filtro HEPA / HEPA-Filter	(EN1822)	H14
Capacità / Volume	lt	13
Bocchettone / Suction inlet	mm	50
Rumorosità / Noise level	dB(A)	74
Classe IP / IP-Class	CL	1
Dimensioni / Dimensions	cm	46 X 48 X 85 h



MISTRAL/ 501 WD



L'aspiratore W&D più compatto della gamma Delfin:

- costruzione 100% in acciaio (INOX disponibile come optional)
- aspirazione liquidi/polveri, galleggiante e filtro liquidi incluso
- accessori D40 inclusi
- filtro stellare polveri più filtro liquidi
- tubo scarico liquidi
- compatto e leggero, ideale per i professionisti del pulito

The most compact W&D vacuum cleaner in the Delfin range:

- 100% steel construction (INOX available as an option)
- suitable for wet & dry service (floating device, wet PPL & dry starfilters included)
- 40 mm accessories kit included
- hose for liquid discharge included
- compact and portable, ideal for cleaning contractors

13

MISTRAL/ 802 WD



Aspiratore industriale W&D per ogni tipo di applicazione

- costruzione 100% in acciaio (INOX disponibile come optional)
- doppio filtro autopulente per polveri
- filtro in polipropilene 300 micron per liquidi
- galleggiante
- accessori D50 inclusi
- compatto e robusto
- disponibile in versione pump con pompa per scarico
- testata con calotta insonorizzata

W&D vacuum cleaner for any kind of application

- 100% Steel construction, compact and sturdy
- self cleaning dry double filter
- PPL anti-foam 300 micron wet filter
- floating device and liquid discharge hose
- 50 mm accessories kit included



PUMP OPTION

		501 WD	802 WD
Tensione / Voltage	V	230 1~	230 1~
Frequenza / Frequency	Hz	50	50
Potenza / Power	kW	1,15	2,3
Depressione / Water Lift	mmH2O	2500	2500
Portata d'aria / Air flow max.	m ³ /h	180	360
Superficie filtrante / Filter surface	cm ²	8.000	8.000
Categoria filtro / Filter Class	(IEC 60335-2-69)	L	L
Capacità / Volume	lt	50	80
Bocchettone / Suction inlet	mm	50	80
Rumorosità / Noise level	dB(A)	74	76
Classe IP / IP-Class	CL	1	1
Dimensioni / Dimensions	cm	52 x 40 x 90 h	53 X 59 X 106 h

Mistral

Aspiratori compatti ad alte prestazioni
High performance compact vacuum cleaner

MISTRAL/ 202 DS



14



Pulizia del filtro tramite sistema a pressione differenziale DUSTOP.
DUSTOP filter cleaning system using pressure differential



2 potenti motori by-pass
Lamb Ametek
2 powerful Lamb-Ametek by-pass motors

Filtro da 3 m2 certificato categoria M
3 m2 filter class M certified



Filtro HEPA H14 disponibile come opzione
Additional H14 HEPA filter available as option



MTL202 disponibile con certificazione TÜV SUD
MTL202 available with TÜV SUD certification

L'aspiratore modello 202 DS, compatto e potente, è il vero best seller della linea industriale leggera Mistral. Le sue caratteristiche uniche ne fanno il migliore prodotto nella propria categoria, senza paragoni sul mercato. Dall'alimentare all'edilizia, dalla farmaceutica al trattamento superfici, l'aspiratore Mistral 202 DS ha risolto e continua a risolvere le esigenze di aspirazione di industrie e professionisti in tutto il mondo. Nessuna applicazione è impossibile per questo piccolo grande aspiratore.

- miglior filtrazione della categoria
- costruzione 100% acciaio
- accessori D40 inclusi
- pulizia del filtro tramite sistema a pressione differenziale DUSTOP
- facilmente trasportabile

The Mistral 202 DS, compact and powerful, is the true best seller of the light industrial Mistral line. Its unique technical features make it the best vacuum cleaner in its category, unmatched on the market. From food industry to constructions, from pharmaceuticals labs to surface preparation operations, the Mistral 202 DS solved and continues to solve cleaning and dust extraction problems of industries and professionals worldwide. No application is impossible for this great compact vacuum cleaner.

- best filtration of the category
- 100% steel construction
- D40 accessories included
- DUSTOP filter cleaning system using pressure differential
- easy to use and transport



MISTRAL/ 202 DS Longopac



La soluzione perfetta per aspirare polveri in sicurezza

- ideale per edilizia e trattamento superfici
- aspirazione in sicurezza di polveri tossiche, fini
- insaccamento progressivo in sacco da 20 mt
- pulizia del filtro tramite sistema a pressione differenziale DUSTOP
- facilmente trasportabile grazie al sistema di regolamento dell'altezza

The perfect solution for a safer suction of dust

- ideal for construction and surface treatment applications
- safe suction of toxic and fine dust
- 20 mt Longopac™ bag for safe collection
- DUSTOP filter cleaning system using pressure differential
- easy to use and to transport thanks to the height adjustment system

MISTRAL/ 202 DS ECO T/M



La soluzione per un utilizzo continuo più compatta della gamma

- miglior filtrazione della categoria
- servizio continuo 24/7
- costruzione acciaio
- accessori D40 inclusi
- pulizia del filtro tramite sistema a pressione differenziale DUSTOP
- facilmente trasportabile

The most compact solution for continuous duty

- highest filtration efficiency in its segment
- suitable for continuous duty 24/7, maintenance free motor
- Steel construction
- D40 mm accessories kit included
- DUSTOP filter cleaning system using pressure differential
- easily transportable

		202 DS	202 DS LP	202 DS ECO T	202 DS ECO M
Tensione / Voltage	V	230 1~	230 1~	400 3~	230 1~
Frequenza / Frequency	Hz	50	50	50	50
Potenza / Power	kW	2,3	2,3	1,8	1,8
Depressione / Water Lift	mmH2O	2500	2500	2300	2300
Portata d'aria / Air flow max.	m³/h	360	360	250	250
Superficie filtrante / Filter surface	cm²	30.000	30.000	30.000	30.000
Categoria filtro / Filter Class	(IEC 60335-2-69)	M	M	M	M
Sup. filtro HEPA / HEPA-Filter Surface	cm²	20.500	20.500	20.500	20.500
Filtro HEPA / HEPA-Filter	(EN1822)	H14	H14	H14	H14
Capacità / Volume	lt	20	20 mt Longopac	20	20
Bocchettone / Suction inlet	mm	50	50	50	50
Rumorosità / Noise level	dB(A)	76	76	70	70
Classe IP / IP-Class	IP	CL. 1	CL. 1	55	55
Dimensioni / Dimensions	cm	59 X 48 X 110 h	50 X 48 X 125 h	50 X 48 X 120 h	50 X 48 X 120 h

Mistral

Aspiratori Compatti Compact Vacuum Cleaner MISTRAL/ 352 DS

16



Attacco per elettro utensili
da 600 Watt
*Power tool electric socket,
max 600 Watt*



Contenitore a sgancio per
svuotamento rapido
*Detachable container for
fast discharge*



2 potenti motori by-pass
Lamb Ametek
*2 powerful Lamb-Ametek
by-pass motors*



Filtro di ampia superficie
certificato categoria L
*High surface filter class L
certified*



Aspiratore industriale compatto altamente versatile

L'aspiratore Mistral 352 DS è l'ideale per la pulizia e la movimentazione di piccole e media quantità di materiali, in particolar modo nell'industria chimicofarmaceutica, nell'alimentare e nell'industria molitoria. Estremamente flessibile e robusto, unisce le caratteristiche di robustezza e prestazioni di un vero aspiratore industriale ad un look accattivante e una facilità di utilizzo estrema.

Multifunctional industrial vacuum cleaner

The Mistral 352 DS vacuum cleaner is ideal for cleaning and handling of small and medium amount of materials, particularly in the chemical-pharmaceutical industry, in the food industry and in the cereals milling industry. Extremely flexible and robust, it combines the features of sturdiness and performance of a true industrial vacuum cleaner with an attractive look and an extreme ease of use.



Vantaggi competitivi

- alto livello di filtrazione
- costruzione acciaio
- accessori D50 inclusi
- pulizia del filtro integrata
- contenitore a sgancio con possibilità di insaccamento
- sensore di efficienza filtro
- disponibile con pneumatici toolman per terreni sconnessi
- aspirazione simultanea di solidi, polveri e liquidi

Competitive advantages

- high level of filtration
- total steel construction
- D50 accessories included
- integrated filter cleaning system
- detachable container with possibility of direct bagging of recovered materials
- filter efficiency sensor
- toolman version with tires for uneven terrain available
- simultaneous aspiration of solids, powders and liquids (with floating device)



352DS Toolman

		352 DS
Tensione / Voltage	V	230 1~
Frequenza / Frequency	Hz	50
Potenza / Power	kW	2,3
Depressione / Water Lift	mmH2O	2500
Portata d'aria / Air flow max.	m ³ /h	360
Superficie filtrante / Filter surface	cm ²	20.000
Categoria filtro / Filter Class	(IEC 60335-2-69)	L
Sup. filtro HEPA / HEPA-Filter Surface	cm ²	28.000
Filtro HEPA / HEPA-Filter	(EN1822)	H14
Capacità / Volume	lt	35
Bocchettone / Suction inlet	mm	80
Rumorosità / Noise level	dB(A)	76
Classe IP / IP-Class	IP	F
Dimensioni / Dimensions	cm	55 X 62 X 125 h

Mistral

Aspiratori compatti ad alte prestazioni
High performance compact vacuum cleaner

MISTRAL/ 3533 - 3534 - 3535



18

Potente e silenziosa turbina a canale laterale caratterizzata
Powerful and silent side channel blower



Filtro di ampia superficie certificato categoria L
High surface filter class L certified



Contenitore a sgancio per svuotamento rapido
Detachable container for fast discharge

Il Mistral 3533 (3534 -3535) è uno dei più compatti e potenti aspiratori industriali trifase nel mondo.

- alto livello di filtrazione
- robusta Costruzione acciaio
- accessori D50 inclusi
- pulizia del filtro integrata
- sensore di efficienza filtro
- massima silenziosità
- 24/7 365 giorni all'anno

The Mistral 3533 - 3534 - 3535 is one of the most compact and powerful three-phase industrial vacuum cleaners in the world.

- high level of filtration
- Sturdy steel construction
- D50 accessories included
- Integrated filter cleaning
- filter efficiency sensor
- extremely silent
- ideal for 24/7 continuous applications

		3533	3534	3535
Tensione / Voltage	V	400 3~	400 3~	400 3~
Frequenza / Frequency	Hz	50	50	50
Potenza / Power	kW	2,2	3	4
Depressione / Water Lift	mmH2O	3000	3000	3200
Portata d'aria / Air flow max.	m ³ /h	300	350	450
Superficie filtrante / Filter surface	cm ²	20.000	20.000	20.000
Categoria filtro / Filter Class	(IEC 60335-2-69)	L	L	L
Sup. filtro HEPA / HEPA-Filter Surface	cm ²	28.000	28.000	28.000
Filtro HEPA / HEPA-Filter	(EN1822)	H14	H14	H14
Capacità / Volume	lt	45	45	45
Bocchettone / Suction inlet	mm	80	80	80
Rumorosità / Noise level	dB(A)	69	69	69
Classe IP / IP-Class	IP	55	55	55
Dimensioni / Dimensions	cm	100 X 55 X 125 h	100 X 55 X 125 h	100 X 55 X 125 h

kit consigliato / recommended kit
TA.0400.0000



MISTRAL/ PHARMA 20 - 30



Pulizia del filtro tramite sistema a pressione differenziale DUSTOP.
DUSTOP filter cleaning system using pressure differential



Filtro da 3 m2 certificato categoria M
3 m2 filter class M certified



Potente e silenziosa turbina a canale laterale carterizzata
Powerful and silent side channel blower

Il Mistral Pharma è un aspiratore specifico per l'industria chimico-farmaceutica e food & beverage.

- miglior filtrazione della categoria
- servizio continuo 24/24
- costruzione acciaio
- filtro di sicurezza integrato
- pulizia del filtro tramite sistema a pressione differenziale DUSTOP
- massima silenziosità

The Mistral Pharma is an industrial vacuum cleaner which has been engineered on the requirements of the pharmaceutical, chemical and food industries.

- *best primary filter in its category*
- *suitable for continuous service 24 hours a day*
- *total steel construction (stainless steel AISI 304 or 316 available)*
- *integrated safety filter*
- *DUSTOP filter cleaning system using pressure differential*
- *extremely silent*

		PHARMA 20	PHARMA 30
Tensione / Voltage	V	400 3~	400 3~
Frequenza / Frequency	Hz	50	50
Potenza / Power	kW	1,8	2,2
Depressione / Water Lift	mmH2O	2.300	3.000
Portata d'aria / Air flow max.	m ³ /h	250	300
Superficie filtrante / Filter surface	cm ²	30.000	30.000
Categoria filtro / Filter Class	(IEC 60335-2-69)	M	M
Sup. filtro HEPA / HEPA-Filter Surface	cm ²	20.500	20.500
Filtro HEPA / HEPA-Filter	(EN1822)	H14	H14
Capacità / Volume	lt	33	33
Bocchettone / Suction inlet	mm	50	50
Rumorosità / Noise level	dB(A)	67	67
Classe IP / IP-Class	IP	55	55
Dimensioni / Dimensions	cm	52 X 69 X 147 h	52 X 69 X 147 h



Aspiratori industriali ad alte prestazioni
High performance industrial vacuum cleaner

DM/ DM3

DM3 disponibile con
certificazione TÜV SUD
DM3 available with
TÜV SUD certification



Avvolgicavo per cavo
di alimentazione
Electric cable reel



Contenitore a sgancio per
svuotamento rapido
Detachable container for
fast discharge



3 potenti motori by-pass Lamb Ametek
3 powerful Lamb-Ametek by-pass motors



Filtro di ampia superficie
certificato categoria L
High surface filter class L
certified

Vano porta accessori e
alloggiamento per doppia curva
Accessory and double bend
housing

Altre versioni / Other version

DM3 DUST H

DM3 PN



Per polveri tossiche di classe H
Suitable for Class H toxic dusts



Pulizia automatica del filtro ad aria compressa
Automatic filter cleaning system



TA.0181.0000 - Kit accessori suggerito Recommended accessories kit



DM3, l'aspiratore industriale per eccellenza. Non esistono applicazioni impossibili per il modello DM3, dall'officina al laboratorio, dall'industria metalmeccanica al cementificio, dalla carpenteria alla bottega artigiana. Si tratta di un modello storico della gamma Delfin sviluppato per rispondere ad una vastissima gamma di necessità di aspirazione. Flessibilità di utilizzo ai massimi livelli.

- estrema flessibilità di applicazione
- aspirazione simultanea polveri, liquidi e solidi
- costruzione 100% acciaio
- scuotifiltro integrato
- filtro stellare di grande superficie

DM3, the industrial vacuum cleaner for excellence. There are no impossible applications for the DM3, from the laboratory to the workshop, from mechanical engineering to the cement industry. This model was developed in its first version, more than 15 years ago, to meet a wide range of requirements. It has been completely re-designed in 2014 in order to make it even more user friendly and versatile, while improving a lot its industrial design.

- extreme flexibility of application
- simultaneous suction of powders, liquids and solids
- 100% steel construction
- innovative container detachment system
- integrated manual filter shaker
- large surface star filter



		DM3
Tensione / Voltage	V	230 1~
Frequenza / Frequency	Hz	50
Potenza / Power	kW	3,45
Depressione / Water Lift	mmH2O	2500
Portata d'aria / Air flow max.	m ³ /h	540
Superficie filtrante / Filter surface	cm ²	20.000
Categoria filtro / Filter Class	(IEC 60335-2-69)	L
Sup. filtro HEPA / HEPA-Filter Surface	cm ²	26.500
Filtro HEPA / HEPA-Filter	(EN1822) optional	H14
Capacità / Volume	lt	100
Bocchettone / Suction inlet	mm	80
Rumorosità / Noise level	dB(A)	76
Classe IP / IP-Class	IP	F
Dimensioni / Dimensions	cm	77 X 66 X 150 h



Aspiratori industriali ad alte prestazioni
High performance industrial vacuum cleaner

DM/ DM40 OIL



TA.0188.0000
Kit accessori suggerito *Recommended accessories kit*



3 potenti motori by-pass Lamb Ametek
3 powerful Lamb-Ametek by-pass motors



Contenitore a sgancio per svuotamento rapido
Detachable container for fast discharge



Filtro da 8000 cm² in classe L
+ filtro antischiuma
*8000 cm² class L filter with
additional anti foam filter*

Controllo visuale livello liquidi
Visual liquid level control

L'aspiratore DM40 Oil nasce per rispondere a tutte le esigenze di estrazione e recupero di liquidi, oli ed emulsioni, anche misti a polvere o fango.

- cestello per separazione trucioli integrato
- indicatore livello di riempimento liquidi
- ciclone integrato
- utilizzo anche in modalità dry, grazie al filtro in poliestere aggiuntivo
- testata intercambiabile, mono, trifase o aria compressa

The DM 40 OIL has been designed to meet the most demanding requirements of extraction and recovery of liquids, oils and emulsions, whether or not mixed with dust or mud.

- *integrated sieve grid for shavings and oil filtration*
- *liquid level indicator*
- *possibility to vacuum even dry materials, thanks to the additional polyester filter*
- *interchangeable motor head, single, three-phase or compressed air*

DM40 OIL

Tensione / Voltage	V	230 1~
Frequenza / Frequency	Hz	50
Potenza / Power	kW	3,45
Depressione / Water Lift	mmH2O	2500
Portata d'aria / Air flow max.	m ³ /h	540
Capacità / Volume	lt	100
Capacità cestello trucioli / Shaving grid volume	lt	40
Galleggiante / Floating device		Si / Yes
Bocchettone / Suction inlet	mm	80
Rumorosità / Noise level	dB(A)	76
Classe IP / IP-Class	IP	F
Dimensioni / Dimensions	cm	67 X 66 X 125 h

DM/ DM 40 WD



Aspiratore W&D per ogni tipo di applicazione industriale

- grande capacità di recupero liquidi
- costruzione 100% acciaio (opzione inox AISI 304)
- galleggiante e valvola di scarico integrata
- kit polveri incluso
- funzionale e maneggevole

W&D industrial vacuum cleaner for any kind of application

- high collection capacity
- 100% steel construction (optional stainless steel AISI 304 or 316)
- integrated floating device and discharge valve
- dry filter included
- functional and handy

DM/ DM 40 SGA



Aspiratore industriale compatto ad alte prestazioni

- estrema flessibilità di applicazione polveri, liquidi, solidi
- costruzione 100% acciaio
- grande capacità di recupero
- scuotifiltro integrato
- filtro stellare di grande superficie

High performance industrial vacuum cleaner

- great flexibility of application
- 100% steel construction
- large capacity detachable container
- integrated filter cleaning system
- large surface star filter



TA.0181.0000 - Kit accessori suggerito -
Accessories kit suggested

DM40SGA disponibile con certificazione TÜV SUD
DM40SGA available with TÜV SUD certification



		DM40 WD	DM40 SGA
Tensione / Voltage	V	230 1~	230 1~
Frequenza / Frequency	Hz	50	50
Potenza / Power	kW	3,45	3,45
Depressione / Water Lift	mmH2O	2500	2500
Portata d'aria / Air flow max.	m ³ /h	540	540
Superficie filtrante / Filter surface	cm ²	8.000	20.000
Categoria filtro / Filter Class	(IEC 60335-2-69)	L	L
Sup. filtro HEPA / HEPA-Filter Surface	cm ²		26.500
Filtro HEPA / HEPA-Filter	(EN1822) optional		H14
Capacità / Volume	lt	120	50
Bocchettone / Suction inlet	mm	80	80
Rumorosità / Noise level	dB(A)	76	76
Classe IP / IP-Class	IP	F	F
Dimensioni / Dimensions	cm	68 x 63 x 125 h	68 x 63 x 125 h



ENTRY LEVEL: grandi prestazioni, minimi costi

ENTRY LEVEL: great performances, minimal costs

DMEL/ DM3 EL



3 potenti motori by-pass Lamb Ametek
3 powerful Lamb-Ametek by-pass motors



Filtro da 20.000 cm² in classe L
20.000 cm² class L filter

Contenitore a sgancio rapido
Detachable container

24

Gli aspiratori della linea DM ENTRY LEVEL sono i prodotti con il miglior rapporto qualità prezzo dell'intera gamma Delfin. Semplicità, concretezza, prestazioni, durata nel tempo sono i valori che li contraddistinguono.

- aspirazione simultanea di solidi, polveri e liquidi
- contenitore a sgancio e possibilità di insaccamento
- filtro a tasche di ampia superficie con sistema di pulizia manuale integrato
- grandissima durata nel tempo

The vacuum cleaners which compose the DM ENTRY LEVEL line are the products with the best value for money in the entire range. Simplicity, practicality, performance, durability are the values that distinguish them.

- Simultaneous suction of solids, powders and liquids
- Detachable container and possibility for direct bagging
- Large surface pocket filter with integrated manual cleaning system
- Great durability

		DM3 EL
Tensione / Voltage	V	230 1~
Frequenza / Frequency	Hz	50
Potenza / Power	kW	3,45
Depressione / Water Lift	mmH ₂ O	2500
Portata d'aria / Air flow max.	m ³ /h	540
Superficie filtrante / Filter surface	cm ²	20.000
Capacità / Volume	lt	60
Bocchettone / Suction inlet	mm	80
Rumorosità / Noise level	dB(A)	76
Dimensioni / Dimensions	cm	67 X 66 X 134 h



DM/ DM3 EL 2M



Aspiratore a due motori compatto per ogni tipo di applicazione industriale

- due potenti motori by-pass
- design industriale, costruzione 100% acciaio (opzione inox AISI 304)
- filtro a tasche di grandi dimensioni
- funzionale e maneggevole

Vacuum cleaner with two by-pass motors for any type of industrial application

- Two powerful by-pass motors
- Industrial design, 100% steel construction (stainless steel option AISI 304)
- Large pocket filter
- Functional and easy to handle

25

DM/ DM3 EL LP



Aspiratore industriale con sistema LONGOPAC®

- ideale per l'utilizzo con macchine per la preparazione delle superfici (levigatrici, pallinatrici, ecc.)
- sistema di raccolta delle polveri LONGOPAC®
- scuotifiltro integrato
- filtro di grande superficie

Industrial vacuum cleaner with LONGOPAC® safe bagging system

- perfect for the application floor preparation machines (grinders, polishers, etc.)
- LONGOPAC® safe bagging dust collection system
- Integrated filter shaker
- Large filter surface



TA.0181.0000 - Kit accessori suggerito - Accessories kit suggested

		DM3 EL 2M	DM3 EL LP
Tensione / Voltage	V	230 1~	230 1~
Frequenza / Frequency	Hz	50	50
Potenza / Power	kW	2,30	3,45
Depressione / Water Lift	mmH2O	2500	2500
Portata d'aria / Air flow max.	m ³ /h	360	540
Superficie filtrante / Filter surface	cm ²	20.000	20.000
Categoria filtro / Filter Class	(IEC 60335-2-69)	L	L
Sup. filtro HEPA / HEPA-Filter Surface OPTIONAL	cm ²	26.500	26.500
Capacità / Volume	lt	60	20 mt Longopac
Bocchettone / Suction inlet	mm	80	80
Rumorosità / Noise level	dB(A)	76	76
Dimensioni / Dimensions	cm	67 X 66 X 134 h	80 x 66 x 155 h



ZEFIRO/ ZEFIRO EL M/T

26



Aspiratore industriale trifase ad alte prestazioni

- estrema flessibilità di applicazione polveri, liquidi, solidi
- costruzione 100% acciaio
- grande capacità di recupero
- scuotifiltro integrato
- filtro stellare di grande superficie

High performance industrial vacuum cleaner

- great flexibility of application (suitable for wet, dry, dust applications)
- powerful and reliable side channel blower
- 100% steel construction
- large capacity detachable container
- integrated filter cleaning system
- large surface star filter



		ZEFIRO EL M	ZEFIRO EL T	ZEFIRO EL T4 HD
Tensione / Voltage	V	230 1~	400 3~	400 3~
Frequenza / Frequency	Hz	50	50	50
Potenza / Power	kW	2,2	2,2	4
Depressione / Water Lift	mmH2O	3000	3000	3200
Portata d'aria / Air flow max.	m ³ /h	330	330	400
Superficie filtrante / Filter surface	cm ²	20.000	20.000	20.000
Categoria filtro / Filter Class	(IEC 60335-2-69)	L	L	L
Sup. filtro HEPA / HEPA-Filter Surface	cm ²	26.500	26.500	26.500
Filtro HEPA / HEPA-Filter	(EN1822)	H14	H14	H14
Capacità / Volume	lt	60	60	60
Bocchettone / Suction inlet	mm	80	80	80
Rumorosità / Noise level	dB(A)	74	74	76
Classe IP / IP-Class	IP	55	55	55
Dimensioni / Dimensions	cm	79 X 66 X 170 h	79 X 66 X 170 h	79 X 66 X 170 h

Kit accessori suggerito / Accessories kit suggested
TA.0181.0000



ZEFIRO/ ZEFIRO 75

Avvolgicavo per cavo di alimentazione
Electric cable reel



Vano porta accessori e alloggiamento per doppia curva
Accessory and double bend housing



Tutta la compattezza di un aspiratore industriale verticale, con la potenza e la resistenza di una turbina a canale laterale. Ecco in sintesi gli straordinari vantaggi dello Zefiro 75, un aspiratore ideale per tutte quelle applicazioni ove sono necessarie grandi prestazioni continuative in spazi relativamente ristretti. L'estrema flessibilità di utilizzo permette a questo modello di operare con efficacia e successo in qualsiasi settore dell'industria.

- best seller della categoria trifase verticale
- super accessorato
- servizio continuativo 24/24, senza manutenzione
- flessibilità di applicazione ed utilizzo in tutti i settori dell'industria
- contenitore a sgancio 100 lt

All the compactness of vertical industrial vacuum cleaner, with the power of a side channel blower. It is the summary of the extraordinary features of ZEFIRO 75. It is an ideal industrial vacuum for all those applications where high performance and high mobility are required in relatively small spaces. The extreme flexibility of use allows this model to operate effectively and successfully in any industry.

- best seller in the three-phase vertical category
- continuous duty service 24/7 motor free of maintenance
- flexibility of application and use in all sectors of industry
- D50 kit recommended accessories (optional)
- 100 liters detachable container

27

ZEFIRO 75

Tensione / Voltage	V	400 3~
Frequenza / Frequency	Hz	50
Potenza / Power	kW	3
Depressione / Water Lift	mmH2O	3000
Portata d'aria / Air flow max.	m ³ /h	350
Superficie filtrante / Filter surface	cm ²	26.500
Categoria filtro / Filter Class	(IEC 60335-2-69)	L
Sup. filtro HEPA / HEPA-Filter Surface	cm ²	20.000
Filtro HEPA / HEPA-Filter	(EN1822)	H14
Capacità / Volume	lt	100
Bocchettone / Suction inlet	mm	80
Rumorosità / Noise level	dB(A)	75
Classe IP / IP-Class	IP	55
Dimensioni / Dimensions	cm	79 X 66 X 170 h



Aspiratori industriali tri-fase ad alte prestazioni
High performance three-phases industrial vacuum cleaner

DG EXP/ DG EXP 30 - 50 -70



DG EXP con certificazione per l'aspirazione di AMIANTO
DG EXP certified for asbestos abatement

28

Vano porta accessori
Accessory gasket



Avvolgicavo per cavo di alimentazione
Electric cable reel



Potente motore trifase
Powerful three-phase motor



Filtro da 3 m2 certificato categoria L
3 m2 filter class L certified



Contenitore a sgancio per svuotamento rapido
Detachable container for fast discharge

La linea DG EXP comprende aspiratori equipaggiati con turbine a canale laterale ad alte prestazioni, per la rimozione di materiali compatti, polveri pesanti, anche miste a corpi solidi.

The DG EXP line is composed of industrial vacuum cleaners equipped with side channel blowers from 2,2 to 5,5 Kw. These sturdy machines are ideal for the removal of solid materials, heavy dust, also mixed with solids.



Disponibile con SPARK TRAP per l'aspirazione di scintille e e polveri incandescenti.

Available with SPARK TRAP system for the safe suction of sparks and white-hot dust.



Il DG EXP nasce dal ultraventennale know how di delfin nella costruzione di aspiratori industriali carrellati. Come la maggior parte dei nostri aspiratori trova applicazione in un serie pressocchè infinita di industrie e settori professionali. Grande capacità, potenza e robustezza ne fanno un investimento sicuro per qualsiasi impresa.

- il più compatto degli aspiratori carrellati trifase
- esente da manutenzione grazie a un soffiante a canale laterale
- alta efficienza di filtrazione
- robusto, compatto e maneggevole

The DG EXP is the direct result of Delfin's twenty years of expertise in the construction of three phase industrial vacuum cleaners. Like most of our vacuum cleaners these find application in almost any industry and professional sector. Large capacity, power and robustness make it a safe investment for any enterprise.

- the most compact of the three-phase vacuum cleaners line with motor in the rear carter
- maintenance-free motor
- high filtration efficiency
- robust, compact and easy to use

		DG EXP 30	DG EXP 50	DG EXP 70
Tensione / Voltage	V	400 3~	400 3~	400 3~
Frequenza / Frequency	Hz	50	50	50
Potenza / Power	kW	2,2	4	5,5
Depressione / Water Lift	mmH2O	3.000	3.200	3.000
Portata d'aria / Air flow max.	m³/h	300	450	550
Superficie filtrante / Filter surface	cm²	20.000	30.000	30.000
Categoria filtro / Filter Class	(IEC 60335-2-69)	L	L	L
Sup. filtro HEPA / HEPA-Filter Surface	cm²	26.500	26.500	52.500
Filtro HEPA / HEPA-Filter	(EN1822)	H14	H14	H14
Capacità / Volume	lt	100	100	100
Bocchettone / Suction inlet	mm	80	80	80
Rumorosità / Noise level	dB(A)	71	72	72
Classe IP / IP-Class	IP	55	55	55
Dimensioni / Dimensions	cm	66 X 118 X 145 h	66 X 118 X 145 h	66 X 118 X 145 h



Aspiratori industriali tri-fase ad alte prestazioni
High performance three-phases industrial vacuum cleaner

DG EXP/ DG 75 - DG 75 AF



30



L'aspiratore più potente e performante della categoria

- potente turbina a canale laterale da 7,5 kW
- elevatissima efficienza di filtrazione
- valvola rompivuoto di serie
- filtro di sicurezza di serie
- ciclone integrato

The most powerfull and the most efficient vacuum cleaner in its category

- *the most powerful motor in its category*
- *outstanding filtration efficiency*
- *integrated safety filter*
- *integrated pressure relief valve*
- *tangential suction inlet with integrated cyclone*





- 1. Filtro stellare / *High surface star filter*
- 2. Filtro di sicurezza / *Safety filter*
- 3. Filtro diffusione / *Diffusion filter*
- 4. Pannello elettrico / *Electric switch*
- 5. Ciclone / *Cyclon*
- 6. Gruppo aspirante / *Side channel blower*
- 7. Valvola limitatrice di vuoto / *Safety valve*
- 8. Leva per sgancio contenitore / *Lever for the detachment of the container*

		DG 75	DG 75 AF
Tensione / <i>Voltage</i>	V	400 3~	400 3~
Frequenza / <i>Frequency</i>	Hz	50	50
Potenza / <i>Power</i>	kW	7,5	7,5
Depressione / <i>Water Lift</i>	mmH2O	4.000	4.000
Portata d'aria / <i>Air flow max.</i>	m ³ /h	530	700
Superficie filtrante / <i>Filter surface</i>	cm ²	49.000	49.000
Categoria filtro / <i>Filter Class</i>	(IEC 60335-2-69)	L	L
Sup. filtro HEPA / <i>HEPA-Filter Surface</i>	cm ²	52.000	52.000
Filtro HEPA / <i>HEPA-Filter</i>	(EN1822)	H14	H14
Capacità / <i>Volume</i>	lt	100	100
Bocchettone / <i>Suction inlet</i>	mm	80	80
Rumorosità / <i>Noise level</i>	dB(A)	76	76
Classe IP / <i>IP-Class</i>	IP	55	55
Dimensioni / <i>Dimensions</i>	cm	66 X 118 X 175 h	66 X 118 X 175 h

NEW

DG VL

Aspiratori industriale per applicazioni pesanti Heavy duty industrial vacuum cleaner

DG VL/ DG VL 75

32



Aspiratori industriale per applicazioni pesanti

- potente e performante
- elevatissima efficienza di filtrazione con sistema semi- automatico di pulizia del filtro SELF CLEAN di serie
- valvola limitatrice di vuoto di serie
- adatto ad applicazioni pesanti e continuative, sia in servizio mobile che su impianti centralizzati

Heavy duty industrial vacuum cleaner

- heavy duty, powerful three phase vacuum
- high filtration, integrated semi-automatic SELF CLEAN filter cleaning system
- integrated pressure relief valve
- suitable for heavy duty applications, both in mobile service and central vacuum systems

DG VL/ DG VL 110



Aspiratori industriale per applicazioni pesanti

- potente e performante
- elevatissima efficienza di filtrazione con sistema semi- automatico di pulizia del filtro SELF CLEAN di serie
- valvola limitatrice di vuoto di serie
- adatto ad applicazioni pesanti e continuative, sia in servizio mobile che su impianti centralizzati

Heavy duty industrial vacuum cleaner

- heavy duty, powerful three phase vacuum
- high filtration, integrated semi-automatic SELF CLEAN filter cleaning system
- integrated pressure relief valve
- suitable for heavy duty applications, both in mobile service and central vacuum systems

		DG VL 75	DG VL 110
Tensione / Voltage	V	400 3~	400 3~
Frequenza / Frequency	Hz	50	50
Potenza / Power	kW	7,5	11
Depressione / Water Lift	mmH2O	4.500	4.000
Portata d'aria / Air flow max.	m ³ /h	750	1.000
Superficie filtrante / Filter surface	cm ²	70.000	70.000
Categoria filtro / Filter Class	(IEC 60335-2-69)	L	L
Sup. filtro HEPA / HEPA-Filter Surface	cm ²	52.000	103.500
Filtro HEPA / HEPA-Filter	(EN1822)	H14	H14
Capacità / Volume	lt	160	160
Bocchettone / Suction inlet	mm	120	120
Rumorosità / Noise level	dB(A)	72	75
Dimensioni / Dimensions	cm	180 X 77 X 200 h	180 X 77 X 200 h



DG VL/ DG VL 125

Aspiratori industriale per applicazioni pesanti

- potente e performante
- elevatissima efficienza di filtrazione con sistema semi- automatico di pulizia del filtro SELF CLEAN di serie
- valvola limitatrice di vuoto di serie
- adatto ad applicazioni pesanti e continuative, sia in servizio mobile che su impianti centralizzati

Heavy duty industrial vacuum cleaner

- heavy duty, powerful three phase vacuum
- high filtration, integrated semi-automatic SELF CLEAN filter cleaning system
- integrated pressure relief valve
- suitable for heavy duty applications, both in mobile service and central vacuum systems



33

DG VL/ DG VL 185

Aspiratori industriale per applicazioni pesanti

- potente e performante
- elevatissima efficienza di filtrazione con sistema semi- automatico di pulizia del filtro SELF CLEAN di serie
- valvola limitatrice di vuoto di serie
- adatto ad applicazioni pesanti e continuative, sia in servizio mobile che su impianti centralizzati

Heavy duty industrial vacuum cleaner

- heavy duty, powerful three phase vacuum
- - high filtration, integrated semi-automatic SELF CLEAN filter cleaning system
- integrated pressure relief valve
- suitable for heavy duty applications, both in mobile service and central vacuum systems



		DG VL 125	DG VL 185
Tensione / Voltage	V	400 3~	400 3~
Frequenza / Frequency	Hz	50	50
Potenza / Power	kW	12,5	18,5
Depressione / Water Lift	mmH2O	4.000	4.000
Portata d'aria / Air flow max.	m ³ /h	1.100	1.350
Superficie filtrante / Filter surface	cm ²	70.000	70.000
Categoria filtro / Filter Class	(IEC 60335-2-69)	L	L
Sup. filtro HEPA / HEPA-Filter Surface	cm ²	103.500	103.500
Filtro HEPA / HEPA-Filter	(EN1822)	H14	H14
Capacità / Volume	lt	160	160
Bocchettone / Suction inlet	mm	120	120
Rumorosità / Noise level	dB(A)	75	76
Dimensioni / Dimensions	cm	180 X 77 X 200 h	180 X 77 X 200 h



Aspiratori industriale per applicazioni pesanti
Heavy duty industrial vacuum cleaner

DG HD/ DG 200 - 300 HD



34

Compressore integrato per pulizia automatica del filtro
Integrated compressor for the automatic cleaning of the filter



Filtro da 12 m² in classe L
12 m² class L filter



Potentissimo motore trifase
Incredibly Powerful threephase motor

Contenitore a sgancio per svuotamento rapido
Detachable container for fast discharge





Gli aspiratori più performanti della gamma Delfin

Tutta la potenza di turbine da 18,5 a 25 kw, sistemi di pulizia dei filtri in controcorrente d'aria integrati, valori di depressione che arrivano fino a 4500 mm H2O, questi sono solo alcuni dei motivi per cui gli aspiratori DG 200 e 300 HD non sono semplici aspiratori industriali, ma veri e propri strumenti per la movimentazione di materiali.

I modelli DG sono macchine capaci di aumentare l'efficienza e la produttività di qualsiasi industria pesante, dai cementifici alle fonderie. ovunque vi siano grandi quantità di materiali (anche diversi metri cubi), anche molto pesanti, questi aspiratori fanno la differenza.

Ideali se utilizzati come centrali aspiranti in un impianto centralizzato in combinazione con i sistemi di separazione Delfin.

Caratteristiche

- migliore rapporto potenza/filtrazione della categoria
- massima trasportabilità
- macchina progettata per l'industria pesante
- scuotifiltro automatico di serie
- Sonda PTC

Best performing vacuum cleaner in the Delfin range

All the power of 18.5 to 25 kw turbines, integrated automatic filter cleaning systems, these are just some of the reasons why the DG 200 and 300 HD are not only industrial vacuum cleaners, but real tools for materials handling.

DG machines are capable of increasing the efficiency and productivity of any industry, from cement plants to foundries. Wherever there are large and heavy amounts of materials (even several cubic meters), these vacuums make the difference.

Best when used as vacuum units on centralized vacuum systems in combination with Delfin's filtering and separating units.

Features

- best power / filtration ratio in their category
- maximum portability and modularity
- machine designed for heavy industry
- automatic filter cleaning system as standard

		DG 200	DG 300 HD
Tensione / Voltage	V	400 3~	400 3~
Frequenza / Frequency	Hz	50	50
Potenza / Power	kW	18,5	25
Depressione / Water Lift	mmH2O	4.400	4.500
Portata d'aria / Air flow max.	m ³ /h	1.350	2.200
Superficie filtrante / Filter surface	cm ²	120.000	120.000
Categoria filtro / Filter Class	(IEC 60335-2-69)	L	L
Sup. filtro HEPA / HEPA-Filter Surface	cm ²	103.500	103.500
Filtro HEPA / HEPA-Filter	(EN1822)	H14	H14
Capacità / Volume	lt	220	220
Bocchettone / Suction inlet	mm	120	120
Rumorosità / Noise level	dB(A)	77	78
Classe IP / IP-Class	IP	65	65
Dimensioni / Dimensions	cm	92 X 220 X 220 h	92 X 220 X 220 h

OPZIONI

Offriamo ai nostri clienti una così vasta gamma di personalizzazioni e opzioni da abbinare ai nostri aspiratori standard, che risulta possibile creare più di 1500 differenti configurazioni diverse.

OPTIONS

We offer our customers such a wide range of customizations and options to be combined with our standard vacuums that it is possible to create more than 1500 configurations.

ELF: EXTRA LARGE FILTER

DG 70 EXP

Superficie filtrante standard / Standard filter surface	cm²	30.000
Superficie filtrante con ELF / Extended filter surface	cm²	49.000
Carico sul filtro / Air load on filter	m³/h/m²	112

36

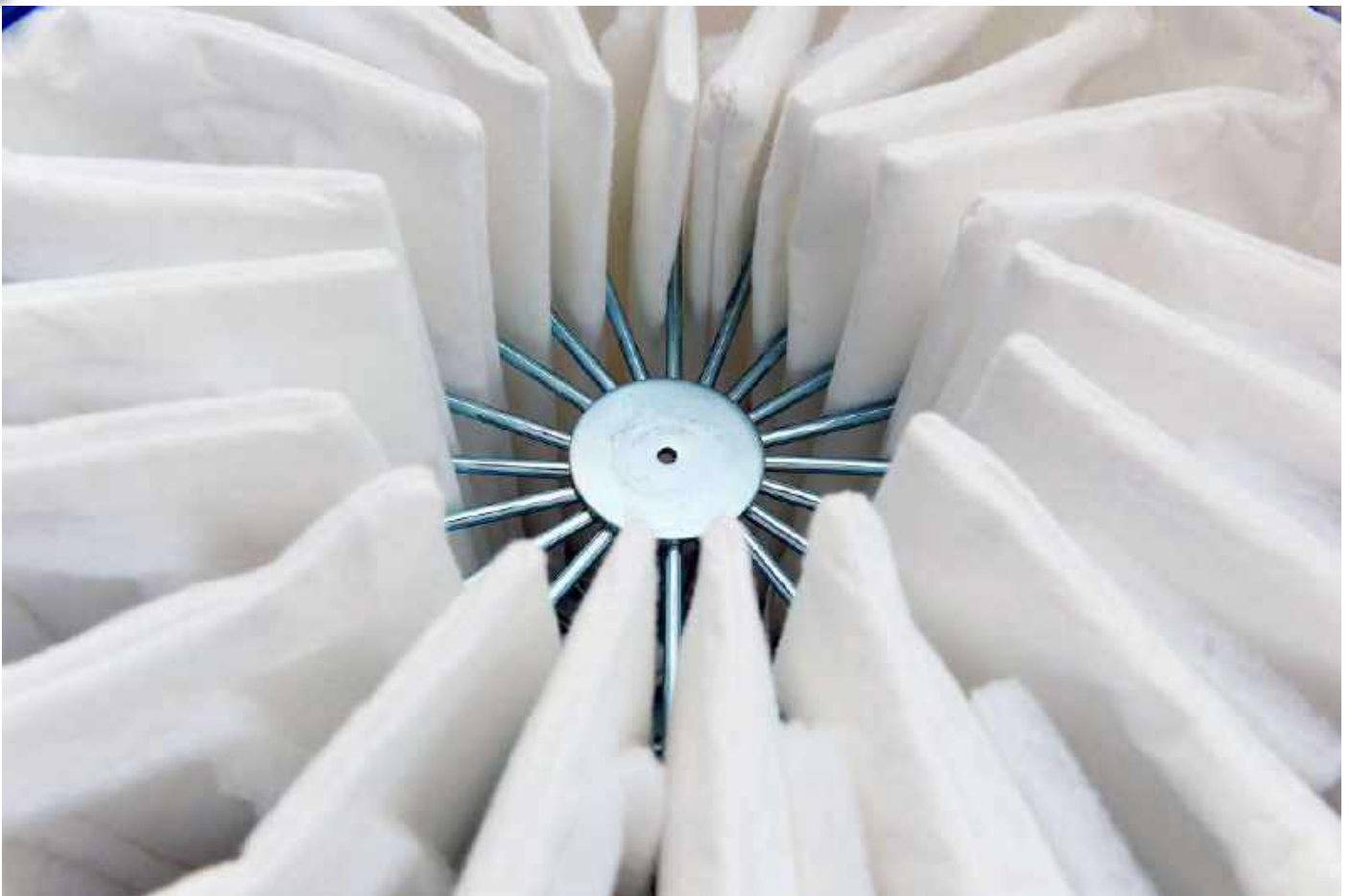

SE: turbina a canale laterale con doppia girante in serie
side channel blower with two turbines in series



DG 50 SE



DG VL 110 SE



DG VL 150 SE



DG 300 SE

Tensione / Voltage	V	400	400	400	400
Potenza / Power	KW	4,3	11	15	20
Depressione / Water lift	mmH₂O	5.100	6.000	6.000	6.000

SISTEMI DI PULIZIA DEI FILTRI *FILTER CLEANING SYSTEMS*

PN: Pulizia automatica del filtro in controcorrente d'aria
Reserve air pulse automatic filter cleaning system.



37

AUT: Scuotifiltro automatico.
Automatic filter cleaning system



NEW

Benne aspiranti per il recupero di grandi quantità di materiali

Vacuuming separators for the collection of large quantities of materials

B200M



Benna aspirante compatta a tre motori monofase

- Ideale per l'aspirazione di grandi quantità di materiale
- Aspirazione generata da 3 potenti motori monofase
- Scarico completo e veloce
- Inforcabile con muletto

Compact, 3 single phase motors vacuuming separator

- Ideal for the suction of large quantities of material
- Suction generated by 3 powerful single phase motors
- Complete and fast discharge of the material thanks to the tilting tank
- Forklift ready

C600M



Benna aspirante a tre motori monofase per grandi quantità

- Ideale per l'aspirazione di grandi quantità di materiale
- Aspirazione generata da 3 potenti motori monofase
- Scarico completo e veloce
- Inforcabile con muletto

Heavy duty single phase vacuuming separator

- Ideal for the suction of large quantities of material
- Suction generated by 3 powerful single phase motors
- Complete and fast discharge of the material thanks to the special design of the tank
- Forklift ready
- Designed for heavy duty applications

		B200 M	C600 M
Tensione / Voltage	V	230 1~	230 1~
Frequenza / Frequency	Hz	50	50
Potenza / Power	kW	3	3,45
Depressione / Water Lift	mmH2O	2.500	2.500
Portata d'aria / Air flow max.	m ³ /h	540	540
Superficie filtrante / Filter surface	cm ²	12.000	30.000
Categoria filtro / Filter Class	(IEC 60335-2-69)	L	L
Capacità / Volume	lt	200	600
Bocchettone / Suction inlet	mm	80	80
Rumorosità / Noise level	dB(A)	77	76
Dimensioni / Dimensions	cm	93 X 81 X 125 h	98 X 125 X 224 h

C600 T75

Benna aspirante trifase per grandi quantità di materiali pesanti

- Ideale per l'aspirazione di grandi quantità di materiale
- Aspirazione generata da una turbina a canale laterale
- costruzione modulare, separatore + unità di aspirazione
- Scarico completo e veloce grazie al separatore staccabile
- Inforcabile con muletto

Heavy duty three phase vacuuming separator

- Ideal for the suction of large quantities of material
- Suction generated a powerful three-phase side channel blower
- Complete and fast discharge of the material thanks to the special design of the tank
- Forklift ready
- Designed for heavy duty applications



39

C600 T125

Benna aspirante trifase per grandi quantità di materiali pesanti

- Ideale per l'aspirazione di grandi quantità di materiale
- Aspirazione generata da una turbina a canale laterale
- costruzione modulare, separatore + unità di aspirazione
- Scarico completo e veloce grazie al separatore staccabile
- Inforcabile con muletto

Heavy duty three phase vacuuming separator

- Ideal for the suction of large quantities of material
- Suction generated a powerful three-phase side channel blower
- Complete and fast discharge of the material thanks to the special design of the tank
- Forklift ready
- Designed for heavy duty applications



		C600 T75	C600 T125
Tensione / Voltage	V	400 3~	400 3~
Frequenza / Frequency	Hz	50	50
Potenza / Power	kW	7,5	12,5
Depressione / Water Lift	mmH2O	4.000	4.000
Portata d'aria / Air flow max.	m ³ /h	700	1.100
Superficie filtrante / Filter surface	cm ²	30.000	30.000
Categoria filtro / Filter Class	(IEC 60335-2-69)	L	L
Capacità / Volume	lt	600	600
Bocchettone / Suction inlet	mm	100	100
Rumorosità / Noise level	dB(A)	75	75
Dimensioni / Dimensions	cm	220 X 100 X 220 h	220 X 100 X 220 h

Potente aspirapolvere industriale per olio, liquido refrigerante e trucioli
Powerful industrial vacuum cleaner for oil, coolant and swarf

TECNOIL/ TECNOIL 100 IF T



40



Sistema di scarico liquidi ad inversione di flusso (100 lt/min)
Flux inversion liquids discharge system (100lt/min)

Potente motore trifase
Powerful three-phase motor



Indicatore visivo del livello dei liquidi
Visual liquid level indicator



Contenitore a sgancio per svuotamento rapido con cestello grigliato per filtrazione trucioli e flotteur integrato
Sieve grid for metal chip filtration with detachable container for fast discharge and floating device

Il tecnoil 100 IF è un aspiratore nato dall'esigenza, manifestata dalle industrie meccaniche di tutto il mondo, di dotarsi di un aspiratore potente e compatto, capace di lavorare in modo continuativo, con costi di acquisto e gestione contenuti. Questo modello soddisfa appieno queste necessità, superando le aspettative degli operatori in ogni parte del mondo.

- esente da manutenzione ordinaria
- lavoro continuativo 24/24
- contenitore a sgancio
- cestello grigliato per separazione trucioli
- valvola rompivuoto

The Tecnoil 100 IF was born from the need, developed in mechanical and engineering industries around the world, to acquire a powerful and compact vacuum cleaner, able to work on continuous duty applications, with low costs of purchase and maintenance. This model fulfills all of these needs, exceeding the expectations of operators in every part of the world.

- motor free from maintenance
- ideal for continuous duty applications 24/7
- detachable container
- sieve grid for the filtration of metal chips
- reverse air flow system for the fast discharge of liquids (100 lt/min avg)



TA.0190.0000 Kit accessori suggerito
Recommended accessory kit



TECNOIL/ TECNOIL 100 IF 3M

L'unione perfetta tra compattezza, potenza e facilità d'uso

- il più potente aspiratore monofase del suo segmento
- sistema di reimmissione liquidi a inversione di flusso
- filtro superwed 3d contro le nebbie oleose
- separazione olio/truciolo integrata
- controllo visivo del livello del liquido recuperato e filtrato

The perfect combination of compactness, power and usability

- the most powerful single phase industrial vacuum of its segment
- independent discharge pump for reintroduction of filtered liquids
- options for oil filtration available from 300 down to 6 microns
- integrated sieve grid for oil / chips separation
- integrated level indicator and floating device



		TECNOIL 100IF	TECNOIL 100IF 3M
Tensione / Voltage	V	400 3~	230 1~
Frequenza / Frequency	Hz	50	50
Potenza / Power	kW	3	3,45
Depressione / Water Lift	mmH2O	3.000	2.500
Portata d'aria / Air flow max.	m³/h	300	540
Capacità / Volume	lt	100	100
Capacità cestello trucioli / Shaving grid volume	lt	40	40
Galleggiante / Floating device		Si / Yes	Si / Yes
Bocchettone / Suction inlet	mm	50	50
Rumorosità / Noise level	dB(A)	78	76
Classe IP / IP-Class	IP	55	55
Dimensioni / Dimensions	cm	67 X 66 X 125 h	67 X 66 X 135 h



TECNOIL/ TECNOIL 200 T

Sistema di scarico liquidi ad inversione di flusso (100 lt/min)
Flux inversion liquid discharge system (100 lt/min)

Potente motore trifase
Powerful three-phase motor

42

Contenitore per liquidi 200 lt capacità con sensore di livello liquidi per lo stop automatico dell'aspiratore a contenitore pieno
Liquids container 200 lt of capacity with sensor for the automatic stop when the tank is full



Contenitore con cestello grigliato per filtrazione trucioli estraibile
Detachable container with integrated sieve grid for metal chips separation

Tecnoil 200 3M



Grazie alla potenza e alla capacità di questa macchina, è possibile recuperare, filtrare dai trucioli ed eventualmente da residui fini (fino a 6 micron) e reimmettere gli oli o le emulsioni nelle macchine CNC. Il Tecnoil 200 permette di minimizzare il fermo macchina per ottenere il massimo della redditività.

- progettato e costruito per l'industria meccanica
- capiente contenitore di recupero
- possibilità di filtraggio dei liquidi aspirati da 300 fino a 6 micron
- pompa indipendente per svuotamento contenitore come opzione

Thanks to the power and the enormous capacity of this machine, you can collect, filter metal chips and pump back into the machine tool oils or emulsions in less than 5 minutes. This machine allows you to minimize the maintenance time, maximizing profitability.

- designed and built for the engineering and mechanical industries
- large recovery container
- possibility of filtering the collected liquids from 300 down to 6 microns
- independent pump for the fast emptying of the container (300 lt/min) optional

TA.01.90.0000



TECNOIL/ TECNOIL 400



L'aspiratore per le medie e grandi industrie meccaniche

- eccellente combinazione di potenza, capacità e compattezza
- sistema per lo scarico dei liquidi ad inversione di flusso (100 lt/min)
- pompa indipendente di reimmissione liquidi disponibili come optional
- filtro superweb 3d contro le nebbie oleose
- separazione olio/truciolo integrata nella tramoggia basculante
- controllo visivo del livello del materiale recuperato

The best pump cleaner for medium to big metalworking factories

- perfect combination of power, capacity and manoeuvrability
- flux inversion liquid discharge system (100 lt/min)
- independent discharge pump for reintroduction of filtered liquids optional
- integrated tilting hopper for easy disposal of solid material (chips, shavings etc.)
- integrated level indicator and floating device

43

TECNOIL/ TECNOIL 600



Il più potente e capiente aspiratore della gamma Tecnoil

- grande potenza per lavoro continuativo 24/24
- massima affidabilità e funzionalità
- enorme capacità di recupero
- pompa per la reimmissione dei liquidi nel ciclo di lavoro
- possibilità di filtrazione degli oli fino a 6 micron
- aspirazione di oli densi, morchia, sedimenti

The most powerful and capacious vacuums cleaner in the Tecnoil range

- great performances even in continuous duty applications
- massive recovery capacity
- powerful Independent discharge pump
- available option for oil filtration down to 6 microns
- able to recover big quantities of dense oil, swarf and sludge

		TECNOIL 200 IF	TECNOIL 200 3M	TECNOIL 400	TECNOIL 600
Tensione / Voltage	V	400 3~	230 1~	400 3~	400 3~
Frequenza / Frequency	Hz	50	50	50	50
Potenza / Power	kW	3	3,45	4	11
Depressione / Water Lift	mmH2O	3.000	2.500	3.600	6.000
Portata d'aria / Air flow max.	m³/h	300	540	400	480
Capacità / Volume	lt	200	200	400	610
Capacità cestello trucioli / Shaving grid volume	lt	40	40	50	75
Galleggiante / Floating device	Automatic Control	Si / Yes	Si / Yes	Si / Yes	Si / Yes
Bocchettone / Suction inlet	mm	50	50	50	60
Rumorosità / Noise level	dB(A)	78	76	76	78
Classe IP / IP-Class	IP	55	55	55	55
Dimensioni / Dimensions	cm	110 x 63 x 181 h	110 x 63 x 147 h	140 X 70 X 180 h	195 X 72 X 195 h



Aspiratori industriali ad aria compressa
Air powered industrial vacuum cleaner

AIR/ 501 WD AIR



44



Il più compatto aspiratore ad aria compressa della gamma Delfin

- compatto e funzionale
- aspirazione di polveri e liquidi
- costruzione in acciaio totalmente made in italy
- funzionale, maneggevole e leggero
- ideale per cantieri navali e applicazione a bordo di navi
- filtro polveri e liquidi di serie

The most compact air driven vacuum cleaner in Delfin range

- compact and portable
- suitable for wet & dry service
- 100% Steel construction
- functional design for maximized user friendliness
- ideal for service aboard ships and in shipyards



Delfin progetta e costruisce una gamma completa di aspiratori alimentati ad aria compressa (senza alcun componente elettromeccanico) di varie capacità e ideali per molteplici applicazioni. Dall'aspirazione di polveri e solidi, ai liquidi, questi aspiratori vengono prevalentemente utilizzati in settori industriali, come i cantieri navali o le applicazioni a bordo di imbarcazioni dove è scomoda o vietata l'alimentazione elettrica.

Questi aspiratori sono equipaggiati con eiettori a venturi (alimentati ad aria compressa), molto sicuri, compatti e che non necessitano di manutenzione ordinaria. Ideali per i cantieri navali, applicazioni a bordo di navi e in tutti i luoghi di lavoro ove l'alimentazione ad aria compressa sia preferibile a quella elettrica.

Delfin designs and manufactures a complete range of air powered vacuum cleaners (without any electromechanical component) of various capacities and ideal for multiple applications. Capable of vacuuming dust, solids and liquids, these vacuum cleaners are mainly used in industries, shipyards or applications on board of ships.

These vacuum cleaners are equipped with Venturi ejectors, extremely safe, compact and which do not require any routine maintenance. Ideal for shipyards, applications on board of ships, oil platforms and in all the workplaces where the air supply is preferable to electricity.

AIR/ 802 WD AIR 1V - 2V



TA.0174.0000 - Kit accessori suggerito - Accessories kit suggested



Aspiratori industriali ad aria compressa

- ottimo rapporto capacità/dimensioni
- prestazioni eccellenti, disponibile anche in versione due venturi
- compatto e robusto
- ideale per cantieri navali e applicazioni a bordo di navi
- kit accessori consigliato (optional)
- indicatore di saturazione filtro

45

Pneumatically driven industrial vacuum cleaner

- great capacity/dimensions ratio
- outstanding performances
- available with 2 Venturi ejectors
- compact and portable
- ideal for service aboard ships and in shipyards



		501 WD AIR	802 WD AIR 1V	802 WD AIR 2V
Tipo di alimentazione / Type of power supply		Aria compressa	Aria compressa	Aria compressa
Alimentazione aria compressa / Compressed air supply	lt/min	1500	1500	3000
Diametro alimentazione / Air supply internal diameter	mm	10	10	10
Pressione d'esercizio / Working pressure	bar	6	6	6
Depressione / Water Lift	mmH2O	4.180	4.180	4.180
Portata d'aria / Air flow max.	m ³ /h	150	150	300
Superficie filtrante / Filter surface	cm ²	8.000	8.000	8.000
Categoria filtro / Filter Class	(IEC 60335-2-69)	L	L	L
Capacità / Volume	lt	50	80	80
Galleggiante / Floating device		Si / Yes	Si / Yes	Si / Yes
Bocchettone / Suction inlet	mm	50	80	80
Rumorosità / Noise level	dB(A)	73	73	73
Dimensioni / Dimensions	cm	52 X 40 X 90 h	53 X 59 X 100 h	53 X 59 X 100 h



Aspiratori industriali ad aria compressa
Air powered industrial vacuum cleaner
AIR/ 202 DS AIR



46



Un aspiratore industriale ad aria compressa dalle caratteristiche uniche

- migliore filtrazione della categoria
- sistema DUSTOP per la pulizia del filtro tramite pressione differenziale
- possibilità di insaccamento diretto
- nessun costo di manutenzione ordinaria
- funzionale e maneggevole
- sensore indicatore di saturazione filtro
- contenitore a sgancio

Air powered industrial vacuum cleaner with unique features

- best filtration of its segment
- DUSTOP filter cleaning system using pressure differential
- detachable container
- direct bagging system available
- maintenance free Venturi suction unit
- light and portable



TA.0184.0000 - Kit accessori suggerito - Accessories kit suggested



DUSTOP

Il sistema di pulizia del filtro a cartuccia DUSTOP è stato introdotto da Delfin al fine di fornire un sistema di pulizia dei filtri per efficienza e funzionalità. Il DUSTOP permette all'operatore di pulire, con la massima efficienza il filtro con un paio di rapide azioni.

- 1) Tappare l'aspirazione (direttamente sul tubo, con il tappo sul bocchettone o con l'apposita ghigliottina)
- 2) Senza spegnere l'aspiratore, aprire per 3/4 volte in rapida successione il flap posto sulla camera.
- 3) Dopo aver pulito perfettamente il filtro, l'operatore può tornare ad aspirare con la massima potenza.

The DUSTOP filter cleaning system was introduced by Delfin in order to provide the best filter cleaning system, with maximum efficiency and functionality. The DUSTOP allows the operator to clean, with great efficiency the filter with two easy actions.

- 1) The operator plugs the vacuum (directly on the hose, with the cap on the suction inlet or with the special guillotine)
- 2) Without switching the vacuum off, the operator opens 3/4 times in rapid succession the flap placed on the chamber.
- 3) The operator, after the cleaning process, can go on vacuuming with the best performance.

AIR/ 352 DS AIR 1V - 2V

TA.0174.0000 - Kit accessori suggerito - Accessories kit suggested



Aspiratore industriale ad aria compressa

- ottime prestazioni di aspirazione (disponibile in versione due venturi)
- lavoro continuativo 24/24
- nessun costo di manutenzione ordinaria
- kit accessori consigliato (optional)
- contenitore a sgancio

Air powered industrial vacuum cleaner

- great suction performances
- available with 2 Venturi ejectors
- maintenance free Venturi suction unit
- integrated filter cleaning system
- compact and easy to transport unit
- detachable container with possibility of using disposable bags



47

		202 DS AIR	352 DS AIR 1V	352 DS AIR 2V
Tipo di alimentazione / Type of power supply		Aria compressa	Aria compressa	Aria compressa
Alimentazione aria compressa / Compressed air supply	lt/min	1500	1500	3000
Diametro alimentazione / Air supply internal diameter	mm	10	10	10
Pressione d'esercizio / Working pressure	bar	6	6	6
Depressione / Water Lift	mmH2O	4.180	4.180	4.180
Portata d'aria / Air flow max.	m ³ /h	150	150	300
Superficie filtrante / Filter surface	cm ²	30.000	20.000	20.000
Categoria filtro / Filter Class	(IEC 60335-2-69)	M	L	L
Filtro HEPA / HEPA-Filter	(EN1822)	H14	H14	H14
Sup. filtro HEPA / HEPA-Filter Surface	cm ²	20.500	28.000	28.000
Capacità / Volume	lt	20	35	35
Bocchettone / Suction inlet	mm	50	80	80
Rumorosità / Noise level	dB(A)	73	73	73
Dimensioni / Dimensions	cm	59 x 48 x 101 h	55 X 62 X 119 h	55 X 62 X 119 h



Aspiratori industriali ad alte prestazioni ad aria compressa
Air powered heavy duty industrial vacuum cleaner

AIR/ DM3 AIR - DM 3 AIR HD



Unità multi-ugelli o doppia unità Venturi
Double Venturi Unit or Multi-jet unit



Filtro da 3 m2 classe L certificato
3 m2 class M certified filter

Avvolgicavo per cavo di alimentazione
Electric cable reel



Vano porta accessori e alloggiamento per doppia curva
Accessory gasket and double bend housing



Contenitore a sgancio rapido, 100 lt di capacità
Detachable container for fast discharge, 100 lt capacity



Due unità venturi o singola unità multiugelli, grande efficienza di filtrazione e 100 lt di capacità di raccolta fanno di questo modello l'ammiraglia della linea ad aria compressa Delfin. Questa macchina si distingue per il miglior rapporto prestazioni/prezzo della categoria.

- il più prestazionale aspiratore ad aria compressa Delfin
- ottima superficie filtrante di serie
- ideale per cantieri navali

Two venturi ejectors or single multi ejector unit, high filtration efficiency and 100 litres of capacity make this model the flagship of Delfin's air powered line.

This machine has the best price / performance ratio in its category.

- *the most powerful air powered vacuum among Delfin's range*
- *wide filtering surface*
- *ideal for shipyards, oil plants and platforms, ships*



AIR/ 200 - 201



Il più potente e performante aspiratore Delfin ad aria compressa

- eccellenti prestazioni di aspirazione, ideale per applicazioni pesanti nei cantieri navali e nelle sabbiature industriali
- tramoggia di grande capacità (200 lt) con scarico a farfalla integrato
- predisposizione per l'inforcatura con muletto
- sistema semi automatico di pulizia del filtro a cartuccia SELF CLEAN

The most powerful and efficient air powered Delfin vacuum cleaner

- great suction performances, ideal for heavy duty applications in the shipyards and industrial sandblasting industry
- easy to transport thanks to the sturdy chassis and the forklift intakes
- high capacity hopper container (200 lt) with throttle valve for fast discharge
- semi automatic filter cleaning systema SELF CLEAN



		DM3 AIR	DM3 AIR HD	AIR 200	AIR 201
Tipo di alimentazione / Type of power supply		Aria compressa	Aria compressa	Aria compressa	Aria compressa
Alimentazione aria compressa / Compressed air supply	lt/min	3000	1530	2100	2500
Diametro alimentazione / Air supply internal diameter	mm	10	10	10	10
Pressione d'esercizio / Working pressure	bar	6	6	6	6
Depressione / Water Lift	mmH ₂ O	4.180	5.000	5.000	5.000
Portata d'aria / Air flow max.	m ³ /h	300	450	530	590
Superficie filtrante / Filter surface	cm ²	30.000	30.000	36.000	36.000
Categoria filtro / Filter Class	(IEC 60335-2-69)	L	L	M	M
Capacità / Volume	lt	100	100	200	200
Bocchettone / Suction inlet	mm	73	74	76	76
Dimensioni / Dimensions	cm	62 X 62 X 160 h	62 X 62 X 160 h	77 X 68 X 198 h	77 X 68 X 198 h



Aspiratori per zone a rischio di esplosione Industrial vacuums for hazardous environments

ATEX è il nome convenzionale della direttiva 94/9/CE dell'Unione Europea per la regolamentazione di apparecchiature (non solo aspiratori industriali) destinate all'impiego in zone con atmosfere esplosive. La direttiva, obbligatoria dall'1° luglio 2003 per tutti gli stati dell'Unione Europea, impone la certificazione ATEX a tutti i prodotti installati in luoghi a rischio di esplosione.

Quando mi serve un aspiratore ATEX?

In linea generale, la direttiva ATEX certifica la presenza dei requisiti necessari degli aspiratori, turbine ed altri macchinari, affinché possano operare in sicurezza nel caso di presenza di gas, nebbie e/o polveri potenzialmente esplosive nell'atmosfera.

ATEX is the conventional name of the directive 94/9/EC of the European Union for the regulation of equipment (not only industrial vacuum cleaners) intended for use in areas at risk of explosion. The directive, which has been mandatory since the 1st of July 2003 in all states of the European Union, requires that all products installed in areas at risk of explosion have an ATEX certification.

When do I need an ATEX vacuum cleaner?

The ATEX directive certifies the presence of the necessary requirements for vacuum cleaners, turbines and other components, allowing them to operate in safety in case of presence of gas, mist, and / or potentially explosive dust in the atmosphere.

50

	Zone Zone	Periodo di tempo durante il quale persiste un'atmosfera esplosiva <i>Duration of occurrence of an explosive atmosphere</i>	Categoria Category
Gas, nebbie o vapori <i>Gas, mist or steam</i>	0	Permanenti, frequenti, per lunghi periodi di tempo <i>Continuously, for a long period, frequently</i>	1G
	1	Occasionalmente <i>Occasionally</i>	2G
	2	Raramente o per brevi periodi <i>Rarerly or for a short period</i>	3G
Polveri <i>Dust</i>	20	Permanenti, frequenti, per lunghi periodi di tempo <i>Continuously, for a long period, frequently</i>	1D
	21	Occasionalmente <i>Occasionally</i>	2D
	22	Raramente o per brevi periodi <i>Rarerly or for a short period</i>	3D





Kit accessori specifici - Specific accessories kit

Più di 30 modelli certificati ATEX

Gli aspiratori industriali Delfin certificati ATEX zona 1, 2, 21 e 22 sono costruiti in modo da evitare qualsiasi rischio di innesco in una situazione potenzialmente esplosiva. Ogni aspiratore è progettato in modo da rispettare alla perfezione le norme di riferimento garantendo sicurezza, qualità e affidabilità. Dall'aspirazione di polveri altamente esplosive all'utilizzo di aspiratori in atmosfere potenzialmente esplosive, la nostra gamma completa di aspiratori e accessori certificati ATEX vi garantisce tutta la sicurezza e l'affidabilità testata di cui avete bisogno.

More than 30 ATEX certified machines

Delfin industrial vacuum cleaners certified for ATEX zone 1, 2, 21 and 22 are manufactured in order to avoid any risk of ignition in a potentially explosive environment. Each vacuum cleaner is designed to comply the higher standards, ensuring safety, quality and reliability. If you have to collect highly explosive dusts or need to use vacuum cleaners in potentially explosive atmospheres, our full range of vacuum cleaners and accessories ATEX-certified guarantees all the security and reliability you need.

51

Aspiratori Industriali ATEX

Delfin offre una vasta gamma di aspiratori industriali certificati ATEX, dai più compatti e resistenti aspiratori trasportabili ai grandi aspiratori e centrali aspirati per sistemi centralizzati. Grazie alla molteplicità delle opzioni disponibili siamo in grado di soddisfare qualunque tipo di richiesta:

- motori certificati dal produttore con potenze che variano da 1,8 a 18,5 kW
- filtro antistatico Classe M standard
- filtro di Classe H di serie per le macchine in zona 21
- struttura in acciaio inox AISI 304 o 316 disponibile
- componenti certificati

ATEX Industrial Vacuum Cleaner

Delfin offers a wide range of industrial vacuum cleaners ATEX certified, from the most compact, transportable and resistant machine to the large fixed one dedicated to centralized vacuum systems. Thanks to the variety of available options we are able to satisfy almost any type of request:

- producer-certified motor with power ranging from 1,8 to 18.5 kW
- antistatic M-Class filter as a standard
- H-Class filter as a standard for machines in zone 21
- stainless steel AISI 304 or 316 construction available
- certified components





Aspiratori industriali ATEX ad aria compressa

Gli aspiratori industriali Delfin ad aria compressa certificati ATEX garantiscono il più alto livello di sicurezza grazie alla totale assenza di componenti elettrici.

- Eccezionali performance di aspirazione grazie alle unità Venutri (1 o 2 a seconda dei modelli)
- Ideali per la raccolta di solidi e liquidi
- Disponibili sia in acciaio verniciato a polvere epossidica che in acciaio inox
- Filtri antistatici ad elevata efficienza di filtrazione
- Adatti all'utilizzo in continuo (24/7) ed esenti da manutenzione ordinaria.

Air powered ATEX industrial vacuum cleaner

Delfin ATEX-certified air powered industrial vacuums cleaners guarantee the highest safety level thanks to the absence of any electrical component.

- Outstanding suction performance thanks to the Venutri units (1 or 2 depending on the model).
- Ideal for collection of solid and liquid
- Available in both powder-coated steel or stainless steel
- Antistatic filters with high filtration efficiency
- Suitable for the 24-hour operation and maintenance-free

Aspiratori industriali ATEX ad aria compressa Air powered ATEX industrial vacuum cleaner



Kit accessori ATEX / ATEX Accessories kit (TA.0199.0000)





Doppia unità Venturi
Double Venturi Unit

Certificazione ATEX zona 1-2, 21-22
ATEX certified for zone 1-2, 21-22



Filtro da 3 m2 classe M
certificato antistatico
3 m2 class M certified
antistatic filter

Contenitore a sgancio
rapido con sacco per rifiuti
tossici, 55 lt di capacità
Detachable container
with safety bag for fast
discharge, 55 lt capacity





Aspiratori per estrazione diretta da linee di produzione *Industrial vacuum cleaners for direct extraction on production lines*

DIRECT X

Direct X (Direct Extraction o estrazione diretta) è la gamma di aspiratori progettata da Delfin per essere integrata su linee e macchinari di produzione. Assolve la funzione di recuperare costantemente gli scarti di lavorazione, anche in spazi ridotti, adattandosi perciò a qualsiasi realtà applicativa. Attraverso il proprio dipartimento di R&S Delfin può personalizzare queste unità, adattandole alle necessità del cliente, al fine di ottenere un prodotto dalle caratteristiche uniche.

Direct X (Direct Extraction) is the range of vacuum cleaners designed by Delfin to be equipped on the lines and production machinery of OEMs. These machine are designed to constantly recover processing waste, even in small spaces, thereby adapting to any application. Through its R&D department Delfin can customize these units, in order to tailor them on the needs and requirements of the customer, therefore obtaining a unit with unique features.

54





DIRECT X/ AS 10 - 20 - 30



Aspirasfridi per linee di confezionamento automatiche

- estrazione degli sfridi di produzione direttamente a bordo macchina.
- grande capacità di raccolta e autonomia di lavoro
- servizio continuativo 24/24
- esenti da manutenzione ordinaria
- livello sonoro minimo
- filtro a sacco di nylon (classe L) e indicatore di efficienza del filtro integrato
- possibilità di integrazione della macchina su linee di produzione

Trims extractors for automatic packaging machine

- direct extraction of production scraps from production machinery or lines
- great capacity and working autonomy, 24/7 continuous duty
- maintenance free motor
- extremely silent
- nylon bag filter (class L) and integrated filter efficiency indicator
- possibility to customize the unit for integration / assembly into production machinery

55

DIRECT X/ AS 70



Aspirasfridi per linee di confezionamento automatiche

- estrazione degli sfridi di produzione direttamente a bordo macchina
- grande capacità di raccolta e autonomia di lavoro
- motore di grande potenza esente da manutenzione ordinaria
- ottimo livello di insonorizzazione
- filtro a sacco di nylon (classe L) e indicatore di efficienza del filtro integrato
- possibilità di integrazione della macchina su linee di produzione

Trims extractors for automatic packaging machine

- direct extraction of production scraps from production machinery or lines
- great capacity and working autonomy, 24/7 continuous duty
- very powerful maintenance free motor
- extremely silent
- nylon bag filter (class L) and integrated filter efficiency indicator
- possibility to customize the unit for integration / assembly into production machinery

		AS 10	AS 20	AS 30	AS 70
Tensione / Voltage	V	400 3~	400 3~	400 3~	400 3~
Frequenza / Frequency	Hz	50	50	50	50
Potenza / Power	kW	0,85	1,8	2,2	5,5
Depressione / Water Lift	mmH2O	2.000	2.300	3.000	3.000
Portata d'aria / Air flow max.	m ³ /h	150	250	300	550
Capacità / Volume	lt	130	130	130	210
Bocchettone / Suction inlet	mm	60	60	60	70
Rumorosità / Noise level	dB(A)	68	68	68	71
Classe IP / IP-Class	IP	55	55	55	55
Dimensioni / Dimensions	cm	59 x 55 x 132 h	59 x 55 x 132 h	59 x 55 x 132 h	63 x 100 x 125 h



Aspiratori a base fissa Fixed industrial vacuum cleaner



DIRECTX/ DBF 10 - 20 - 30

56



Unità compatta per estrazione materiali a bordo macchina

- lavoro continuativo 24/24
- sistema di filtrazione e pulizia del filtro integrato
- nessun costo di manutenzione ordinaria
- modularità degli elementi per installazione su linee di produzione

Compact suction unit for direct extraction of scraps or dust

- maintenance free motor, suitable for continuous duty applications 24/7
- high surface dry filter and integrated filter cleaning system
- highly modular and suitable for integration on OEM machines and production lines



Gli aspiratori industriali della linea Direct X DBF e DBFV sono particolarmente adatti per l'estrazione da macchine utensili. Polvere e altri scarti di produzione sono raccolti alla fonte e depositati in modo sicuro. Grazie alla loro compattezza soddisfano tutti i requisiti in termini di ingombri e rumorosità.

Direct X DBF and DBFV industrial vacuum cleaners are particularly suitable for the extraction from machine tools. Dust and other production waste are collected at source and stored securely. Thanks to their compactness they comply with most requirements in terms of size and noise.

		DBF 10	DBF 20	DBF 30
Tensione / Voltage	V	400 3~	400 3~	400 3~
Frequenza / Frequency	Hz	50	50	50
Potenza / Power	kW	0,85	1,8	2,2
Depressione / Water Lift	mmH ₂ O	2.000	2.300	3.000
Portata d'aria / Air flow max.	m ³ /h	150	250	300
Capacità / Volume	lt	25	25	25
Superficie filtrante / Filter surface	cm ²	8.000	8.000	8.000
Categoria filtro / Filter Class	(IEC 60335-2-69)	L	L	L
Filtro HEPA / HEPA-Filter	(EN1822)	H14	H14	H14
Bocchettone / Suction inlet	mm	50	50	50
Rumorosità / Noise level	dB(A)	70	70	74
Classe IP / IP-Class	IP	55	55	55
Dimensioni / Dimensions	cm	35 X 70 X 50 h	35 X 70 X 50 h	35 X 70 X 50 h



DIRECTX/ DBFV 05 - 10 - 20 - 30



Unità compatta per estrazione materiali a bordo macchina

- lavoro continuativo 24/7
- sistema di filtrazione e pulizia integrato
- nessun costo di manutenzione ordinaria
- livello di rumorosità estremamente contenuto

Compact suction unit for direct extraction of scraps or dust

- maintenance free motor, suitable for continuous duty applications 24/7
- high surface dry filter and integrated filter cleaning system
- highly modular and suitable for integration on OEM machines and production lines

Altre versioni / Other options



con filtro HEPA
with added HEPA filter



con cappa aspirante per estrazione
diretta di polveri
with suction arm for the direct
extraction of dust and powders



DBFV 30

		DBFV 05	DBFV10	DBFV 20	DBFV 30
Tensione / Voltage	V	400 3~	400 3~	400 3~	400 3~
Frequenza / Frequency	Hz	50	50	50	50
Potenza / Power	kW	0,4	0,85	1,8	2,2
Depressione / Water Lift	mmH2O	1.750	2.000	2.300	3.000
Portata d'aria / Air flow max.	m ³ /h	100	150	250	300
Capacità / Volume	lt	25	25	25	40
Superficie filtrante / Filter surface	cm ²	8.000	8.000	8.000	8.000
Categoria filtro / Filter Class	(IEC 60335-2-69)	L	L	L	L
Filtro HEPA / HEPA-Filter	(EN1822)	H14	H14	H14	H14
Bocchettone / Suction inlet	mm	50	50	50	50
Rumorosità / Noise level	dB(A)	65	69	69	70
Classe IP / IP-Class	IP	55	55	55	55
Dimensioni / Dimensions	cm	41 X 38 X 70 h	41 X 38 X 70 h	41 X 38 X 70 h	41 X 61 X 101 h



Aspirafusso per il recupero da impianti di saldatura ad arco sommerso *Flux recovery for submerged arc welding systems*

VANTAGGI

- + costruzione modulare e molteplici possibilità di configurazione
- + flessibilità garantita da un dipartimento di ricerca e sviluppo capace di sviluppare soluzioni basate sulle esigenze del cliente
- + disponibilità alla coprogettazione di sistemi integrati con la macchina saldatrice

ADVANTAGES

- + *Modular construction and multiple design options*
- + *Flexibility provided by a research and development department able to develop solutions based on customer needs*
- + *Availability to co-design of integrated systems with welding machine*

Unità fissa
Fixed unit

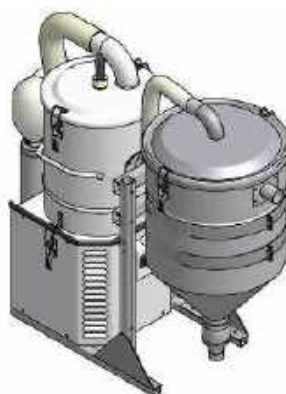

Unità mobile
Mobile unit



Due unità separate, totale modularità di costruzione
Two separate Units, complete modularity





Delfin progetta e costruisce una gamma di aspirafusso per il recupero del flusso di saldatura integrato nel processo di lavorazione. La nostra linea di aspirafusso presenta varie soluzioni di unità aspiranti più tramogge, mobili o fisse, per applicazione continua o alternata, capaci di soddisfare e superare le aspettative e necessità in ogni applicazione industriale.

- diverse soluzioni a seconda delle esigenze
- integrata su telaio unico (fisso o mobile)
- elementi di aspirazione e raccolta separati per montaggio su saldatrice
- tramoggia per separazione flusso
- valvola di scarico per reimmissione flusso

Delfin designs and manufactures a wide range of flux recovery units specifically engineered for the recovery of welding flux, which are integrated in the welding machines. There are several solutions to choose from among, suction units, hoppers, mobile or fixed, which will surely be able to meet and exceed the expectations of workers worldwide.

- different solutions depending on the needs
- integrated on a single frame (fixed or mobile)
- completely customized solutions on demand
- hopper for flux separation
- drain valve for re-use of the flux

		AF 20	AF 30
Tensione / Voltage	V	400 3~	400 3~
Frequenza / Frequency	Hz	50	50
Potenza / Power	kW	1,8	2,2
Depressione / Water Lift	mmH2O	2.300	3.000
Portata d'aria / Air flow max.	m ³ /h	250	300
Capacità / Volume	lt	50	50
Superficie filtrante / Filter surface	cm ²	12.000	12.000
Categoria filtro / Filter Class	(IEC 60335-2-69)	L	L
Bocchettone / Suction inlet	mm	50	50
Rumorosità / Noise level	dB(A)	69	70
Classe IP / IP-Class	IP	55	55
Dimensioni / Dimensions	cm	43 X 50 X 102 h	43 X 50 X 102 h

Aspiratori industriali per camere bianche *Industrial vacuum cleaners for clean rooms*

La camera bianca, in inglese "clean room", è un ambiente la cui caratteristica principale è la presenza di aria molto pura, cioè a bassissimo contenuto di microparticelle di polvere in sospensione. Questa tipologia di laboratorio è molto utilizzata nell'ambito della produzione chimica, farmaceutica, nella meccanica di precisione e nell'elettronica.

60

Lo scopo delle camere bianche è quello di preservare i processi che avvengono al loro interno dalla contaminazione. E' pertanto fondamentale, per la corretta manutenzione ed igienizzazione di queste aree, l'utilizzo di strumenti di pulizia idonei.

Gli aspiratori Delfin per clean rooms sono macchine estremamente specifiche, ingegnerizzate sulle specifiche richieste delle aziende utilizzatrici. Sono disponibili modelli specifici per l'aspirazione di materiali solidi, polverosi, umidi o liquidi.

The clean room is an environment whose main feature is the presence of very pure air, with a very low level of airborne dust microparticles. This type of laboratory is very much used in the field of chemical production, pharmaceuticals, precision mechanics and electronics.

The purpose of the clean room is to preserve the processes that occur within them from contamination. The use of properly designed and manufactured industrial vacuum cleaner is therefore essential, for the proper maintenance and sanitation of these areas.

Delfin's vacuums for clean rooms are very specific machines, engineered on the unique requirements of the users. A range of specialized models are available for the extraction of solid, dusty, humid or liquid materials.



LC / LC1000D - LC1100WD - LC1100S



LC1000D

- + costruzione totale in acciaio inox
- + autoclavabile (fino a 120°, tranne la testata motore)
- + conforme agli standard GMP
- + potente e compatto
- + possibilità di insaccamento del materiale aspirato
- + **specifico per l'aspirazione di solidi e polveri**



LC1100WD

- + costruzione totale in acciaio inox
- + autoclavabile (fino a 120°, tranne la testata motore)
- + conforme agli standard GMP
- + potente e compatto
- + **specifico per l'aspirazione di materiali umidi o liquidi, anche misti a polveri.**



LC1100DS

- + costruzione totale in acciaio inox
- + autoclavabile (fino a 120°, tranne la testata motore)
- + conforme agli standard GMP
- + potente e compatto
- + possibilità di insaccamento in "safe-bag" per rifiuti tossici
- + fino a 4 stadi di filtrazione installabili



		LC1000D	LC1100WD	LC1100DS
Tensione / Voltage	V	230 1~	230 1~	230 1~
Frequenza / Frequency	Hz	50	50	50
Potenza / Power	kW	1	1,1	1,1
Depressione / Water Lift	mmH2O	2.350	2.500	2.500
Portata d'aria / Air flow max.	m³/h	180	180	180
Capacità / Volume	lt	5	40 (25liq)	25 (9liq)
Superficie filtrante / Filter surface	cm²	2.000	2.000	2.000
Categoria filtro / Filter Class	(IEC 60335-2-69)	M	M	M
Filtro HEPA / HEPA-Filter	(EN1822)	H14 (U15 opt)	H14 (U15 opt)	H14 (U15 opt)
Bocchettone / Suction inlet	mm	38	38	38
Rumorosità / Noise level	dB(A)	70	75	75
Classe IP / IP-Class	IP	55	55	55
Dimensioni / Dimensions	cm	41 X 38 X 70 h	41 X 38 X 70 h	55 X 42 X 99 h

Elettroventilatori industriali

Industrial vacuum unit with high airflow

AIRFLOW/ EV 420 - EV AP 500 - EV AP 560



62



Elettroventilatori industriali con grande portata d'aria

- contenitore estraibile da 100 litri, permette un facile smaltimento della polvere raccolta
- filtro di elevata superficie
- scuotifiltro manuale integrato che permette la costante pulizia del filtro
- infinite possibilità di personalizzazione grazie ad una vasta scelta di filtri, sistemi di pulizia e di automazione

Industrial dedusters with high airflow

- 100 Lt removable container, it allows the easy disposal of the collected dust
- wide surface area Filter
- integrated manual filter shaker, enables constant cleaning of the filter
- endless customization options thanks to a wide choice of filtration and automation options

Airflow è la gamma Delfin che comprende elettroventilatori e sistemi di depolverazione. Dall'aspirazione dei fumi di saldatura, all'estrazione e filtrazione di solventi o polveri, l'ampiezza della linea Airflow ci permette di proporre sempre le soluzioni più adeguate alle esigenze del cliente.

Forte della propria divisione di Ricerca e Sviluppo Delfin progetta, propone ed installa sistemi centralizzati di depolverazione ed estrazione di fumi.

Airflow is Delfin's range of dust extractors and dedusting systems. From the vacuuming of welding fumes, to the extraction and filtration of powders, the flexibility of the Airflow line allows us to always offer the most appropriate solution to the customer's needs.

Thanks to its R&D division Delfin engineers, proposes and installs centralized dedusting system and fumes extraction.

		EV 420	EV AP 500	EV AP 560
Tensione / Voltage	V	400 3~	400 3~	400 3~
Frequenza / Frequency	Hz	50	50	50
Potenza / Power	kW	0,75	2,2	4
Depressione / Water Lift	mmH2O	180	280	200-300-350
Portata d'aria / Air flow max.	m ³ /h	1.000	1.300	2.700-1.800-1.100
Capacità / Volume	lt	35	100	100
Superficie filtrante / Filter surface	cm ²	20.000	30.000	50.000
Categoria filtro / Filter Class	(IEC 60335-2-69)	L	L	L
Bocchettone / Suction inlet	mm	100	150	200-150-120
Dimensioni / Dimensions	cm	52 x 60 x 180 h	62 x 62 x 220 h	78 x 85 x 250 h

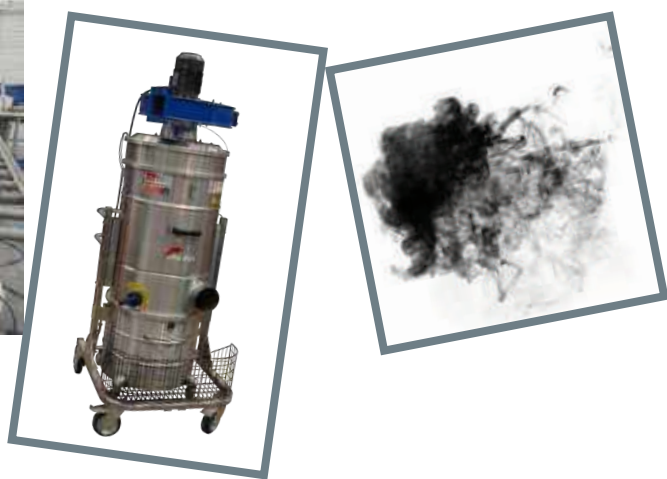

AIRFLOW/ EV PN



Elettroventilatore con grande portata d'aria e pulizia automatica del filtro

- elettroventilatore con grande portata d'aria
- sistema di pulizia automatica dei filtri a cartuccia in controcorrente d'aria
- contenitore estraibile da 100 litri, permette un facile smaltimento della polvere raccolta
- filtro di elevata superficie

Industrial vacuum unit with high airflow and automatic filter cleaning system with reverse air pulse

- vacuum unit with high airflow
- reverse air pulse automatic filter cleaning system
- 100 Lt removable container, it allows easy disposal of collected dust
- wide surface area Filter

L'elettroventilatore della linea Airflow EV PN è la migliore combinazione di portata d'aria ed efficienza. È dotato di un sistema automatico di pulizia del filtro in controcorrente d'aria, chiamato sistema PN. Il sistema è costituito da un contenitore di aria compressa, che si trova dietro la camera filtrante. Ogni 30 secondi (a seconda delle impostazioni), il sistema soffia un getto d'aria compressa a 6 Bar nella cartuccia permettendo il distacco delle particelle di polvere dalla superficie del filtro. Questo sistema permette una pulizia efficiente delle cartucce filtranti senza fermare la macchina.

The Airflow EV PN is the best combination of airflow and efficiency. It's equipped with an automatic filter cleaning system with reverse air pulse, also called PN system. The system consists of a compressed air container, which is placed behind the filter chamber. Every 30 seconds (depending on the settings), the system blows a 6 Bar strong blast of compressed air in the cartridge filters detaching the dust particles from the filter surface. This system allows an efficient cleaning of the filter cartridges without stopping the machine.

		EV PN	EV PN 180	EV PN 150	EV PN 120
Bocchettone / Suction inlet	mm	150	180	150	120
Tensione / Voltage	V	400 3~	400 3~	400 3~	400 3~
Frequenza / Frequency	Hz	50	50	50	50
Potenza / Power	kW	2,2	4	4	4
Depressione / Water Lift	mmH2O	280	200	300	350
Portata d'aria / Air flow max.	m ³ /h	1.300	2.700	1.800	1.100
Capacità / Volume	lt	100	100	100	100
Superficie filtrante / Filter surface	cm ²	106.000	106.000	106.000	106.000
Categoria filtro / Filter Class	(IEC 60335-2-69)	M	M	M	M
Dimensioni / Dimensions	cm	78 x 85 x 250 h	78 x 85 x 250 h	78 x 85 x 250 h	78 x 85 x 250 h

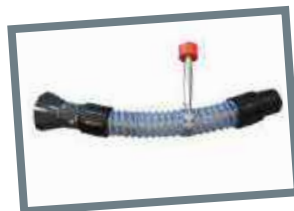

Aspiratore per fumi di saldatura
Industrial vacuum cleaners for welding fumes
AIRFLOW/ 301 TORCH

64



Il miglior modo per aspirare i fumi di saldatura alla fonte

- Aspirazione di fumi di saldatura attraverso il collegamento alla torcia o tramite braccio di aspirazione magnetico
- Filtrazione ad alta efficienza dei fumi la salvaguardia della salute dell'operatore
- Facilità d'uso grazie al controllo remoto legato all'accensione e spegnimento della saldatrice

The best industrial vacuum cleaners to extract welding fumes at the source

- Suction of welding fumes through the connection to the torch or by through the magnetic extraction arm
- High efficiency filtration of fumes in order to safeguard the operator's health
- Easy to use thanks to the remote control which powers on and off the vacuum depending on the operations of the welding machine



controllo remoto
remote control



filtro in classe M
class M filter



filtro anti scintilla
anti spark filter



sistema di pulizia filtri DUSTOP
DUSTOP filter cleaning system

		301 TORCH	302 TORCH	301 ECO TORCH
Tensione / Voltage	V	230 1~	230 1~	400 3~
Frequenza / Frequency	Hz	50	50	50
Potenza / Power	kW	1,15	2,3	1,8
Depressione / Water Lift	mmH2O	2.500	2.500	2.300
Portata d'aria / Air flow max.	m ³ /h	180	360	250
Capacità / Capacity	lt	13	13	13
Superficie filtrante / Filter surface	cm ²	7.500	7.500	7.500
Categoria filtro / Filter Class	(IEC 60335-2-69)	M	M	M
Bocchettone / Suction inlet	mm	50	50	50
Dimensioni / Dimensions	cm	40 x 50 x 86 h	40 x 50 x 86 h	40 x 50 x 130 h



AIRFLOW

Depolveratori ad alte prestazioni / *High performance dedusting systems*



Sistemi di depolverazione ad alte prestazioni

- costruzione totalmente in acciaio 100%
- adatto all'utilizzo in continuo (24/7)
- filtri a cartuccia ad ampia superficie
- pulizia automatica del filtro inclusa
- adatto all'utilizzo mobile o con sistemi centralizzati

High performance dedusting systems

- extremely sturdy 100% steel chassis
- suitable for continuous duty applications 24/7
- extra-large cartridge filter
- automatic filter cleaning system
- suitable for both mobile and fixed use

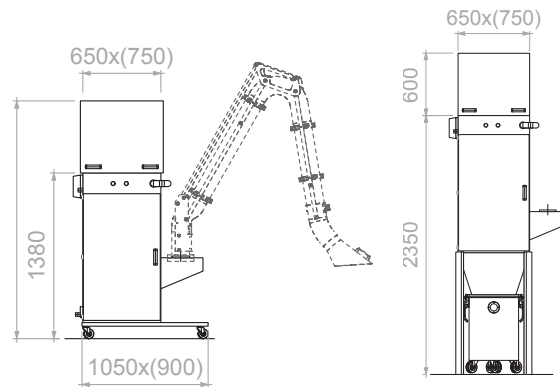

Disponibile in versione mobile con braccio o fissa
Available in fixed or mobile version (with suction arm)

		EVO 2B	EVO 3B	EVO 3C	EVO 4
Tensione / Voltage	V	400 3~	400 3~	400 3~	400 3~
Frequenza / Frequency	Hz	50	50	50	50
Potenza / Power	kW	1,5	1,5	2,2	3
Portata d'aria / Air flow max.	m ³ /h	1.500	1.800	2.200	3.500
Capacità / Capacity	lt	30	30	30	30
N° cartucce / N° cartridges		2	3	3	4
Superficie filtrante / Filter surface	cm ²	200.000	300.000	300.000	650.000
Categoria filtro / Filter Class	(IEC 60335-2-69)	M	M	M	M
Bocchettone / Suction inlet	mm	150	150	150	250
Dimensioni / Dimensions	cm	105 x 90 x 138 h	105 x 90 x 138 h	105 x 90 x 138 h	80 x 80 x 230 h

PRE-SEPARATORI / PRE-SEPARATORS

Delfin propone una vasta gamma di contenitori, preseparatori e preseparatori filtranti con capacità fino a 1000 litri (capacità maggiori disponibili su richiesta). Un preseparatore abbinato al giusto sistema di aspirazione Delfin può aumentarne l'efficienza fino quasi a raddoppiarla, andando inoltre ad alleggerire il carico specifico sul filtro e aumentandone la longevità.

Delfin manufactures a wide range of containers, preseparators and preseparators with filter up to 1,000 liters as standard (bigger capacity available on request). A preseparator in conjunction with an appropriate Delfin vacuum system can double the efficiency of the whole system and extend filter life by decreasing the air load.

Pre-Separatori mobili
Mobile Pre-Separators



66

Pre-Separatori per sostanze incandescenti
Pre-separators for hot materials

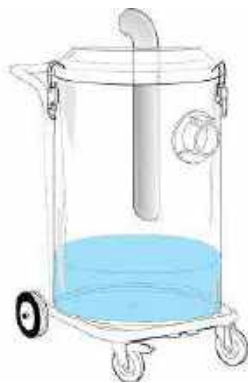

Pre-Separatori mobili, ribaltabili di grande capacità
Tilting pre-separators, high capacity (400 - 600 Lt)





Separatori mobili con scarico Longopac per trattamento superfici | *Separators with Longopac discharge system for floor preparation*



Separatori per il recupero di polveri infiammabili o esplosive
Separators for the collection of explosive or flammable dust

Pre-Separatori mobili, studiati sulle esigenze del cliente
Mobile pre-separators, customized on the client's requirements

Portata d'aria tra / Airflow between 300 - 1000 m³/h



Coperchi Pre-Separatori
Drum top pre-separators

Portata d'aria tra / Airflow between 200 - 500 m³/h



Pre-Separatori filtranti mobili per polveri, solidi e liquidi
Pre-separators with filters for solids, dust and liquids

Portata d'aria tra / Airflow between 300 - 600 m³/h

ACCESSORI / ACCESSORIES



Questi accessori rappresentano solo una parte della vasta gamma disponibile. Delfin può fornire il giusto accessorio per ogni applicazione.

These accessories are only a small selection of Delfin's wide range. Delfin can provide the right tool for every application.

68

TECNOIL (OLIO E TRUCCIOLI) / OIL AND SHAVINGS



202DS KIT



ATEX



MECCANICA / ENGINEERING KIT



FORNI / OVEN CLEANING KIT



ANTISTATICO / ANTISTATIC KIT



Aspirapolvere W&D per uso commerciale
W&D vacuum cleaners for commercial purpose

STORM/ SV 10



STORM/ SV 30



STORM/ SV 60



MODELLO / MODEL	POTENZA / POWER	VERSIONE / VERSION
SV 10	1.000 Watt	14 lt - solidi / dry
SV 30	1.400 Watt	27 lt - solidi-liquidi / wet-dry
SV 60	2.400 Watt	58 lt - solidi-liquidi / wet-dry



Impianti centralizzati di aspirazione *Centralized vacuum systems*

Un impianto centralizzato di aspirazione permette di rimuovere e trasportare materiale da una zona a un'altra, attraverso una serie di tubazioni fisse, e di accumularle e scaricarle in un punto prescelto. Gli impianti di aspirazione industriale Delfin lavorano grazie a tre elementi principali:

- A) un'unità di aspirazione, posta spesso a notevole distanza (decine o centinaia di metri) dal punto (o punti) in cui avviene l'aspirazione del materiale;
- B) un'unità di filtrazione;
- C) un'unità di raccolta. Ogni impianto di aspirazione deve essere progettato in base alle specifiche dimensioni e caratteristiche della zona in cui deve essere installato, e delle prestazioni di aspirazioni richieste.

Centralized Vacuum System allows you to easily clean a wide area and/or to transport the vacuumed material from one area to another, through a series of fixed pipings, accumulating and discharging them in a chosen point. Delfin's centralized installations work with three main elements:

- A) a suction unit, placed often at considerable distance (tens or hundreds of meters) from the point (or points) in which the suction of the material takes place;*
- B) a filtration unit;*
- C) a collection unit. Each CVS must be designed according to the specific dimensions and characteristics of the area in which it has to be installed, taking in account the required performances and the specific application.*

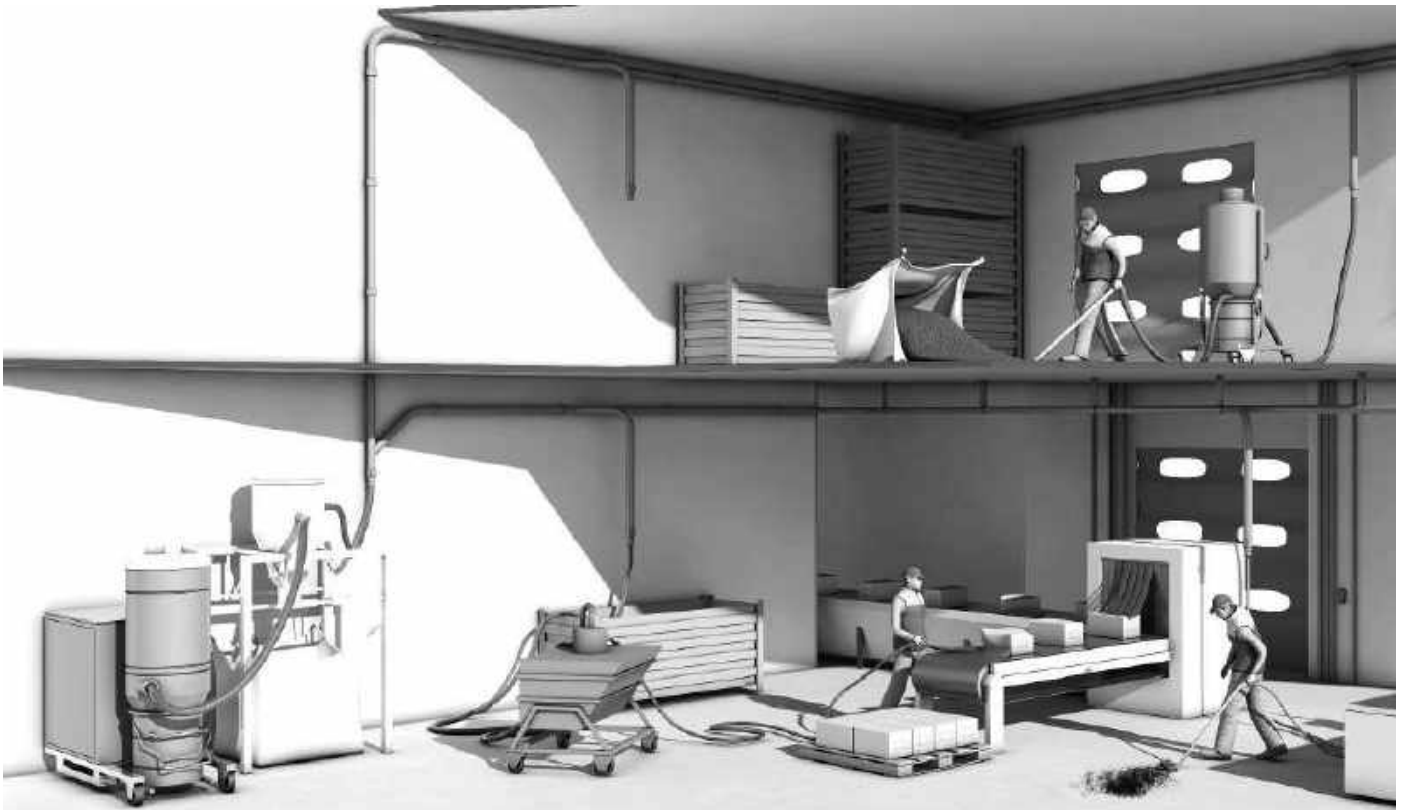

AS FIXE T/M



Unità di aspirazione, filtrazione e raccolta integrata

- versione monofase o trifase per servizio continuativo 24/24
- fissaggio a muro o su telaio a pavimento (anche telaio su ruote)
- scarico a paletta bilanciata
- interruttore a distanza (lunghezza cavo 2 mt)

Suction, filtration and collection integrated unit

- single-phase or three-phase version, suitable for continuous duty applications 24/7
- can be fixed on walls or on metal frames (also on wheels)
- weighed flap discharge system
- remote control switch included (2 mt of cable as standard)

71

Separatori filtranti / Filtering separators



Tramogge filtranti con capacità fino a 1000 litri Filtering hoppers with high capacity, up to 1000 lt.

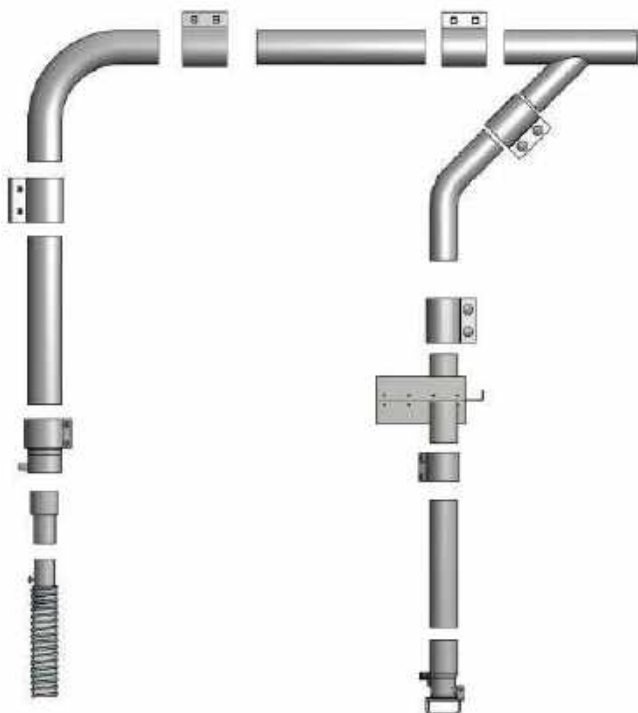

Componenti per impianti centrali Centralized vacuum systems accessories

Delfin può fornire tutta la componentistica necessaria per la realizzazione di un impianto di aspirazione centralizzato. Tubazioni, bocchette, deviazioni in acciaio zincato o INOX sono pronte per essere spedite rapidamente dai nostri magazzini.

Delfin can provide all the necessary components for the realization of a centralized vacuum system.

Pipes, vents, deviations in galvanized or stainless steel are ready to be shipped quickly from our warehouse.

Soluzioni di aspirazione costruite sulle tue esigenze

Customized suction solutions engineered on your requests

Esecuzioni speciali: un mondo di possibilità

La vasta gamma di aspiratori industriali Delfin non soddisfa tutte le vostre esigenze? Nessun problema. I nostri ingegneri sono sempre pronti a sviluppare una soluzione su misura per voi. Con più di 1500 modelli speciali già sviluppati Delfin è il leader delle soluzioni di aspirazione su misura.

Customized industrial vacuums: a world of possibilities

Delfin's wide range of standard vacuum cleaners does not meet all your requirements? Don't worry! Our engineers are always ready to develop a customized solution just for you. With more than 1.500 customized units already engineered, Delfin is the leader in the tailor made vacuum solutions.

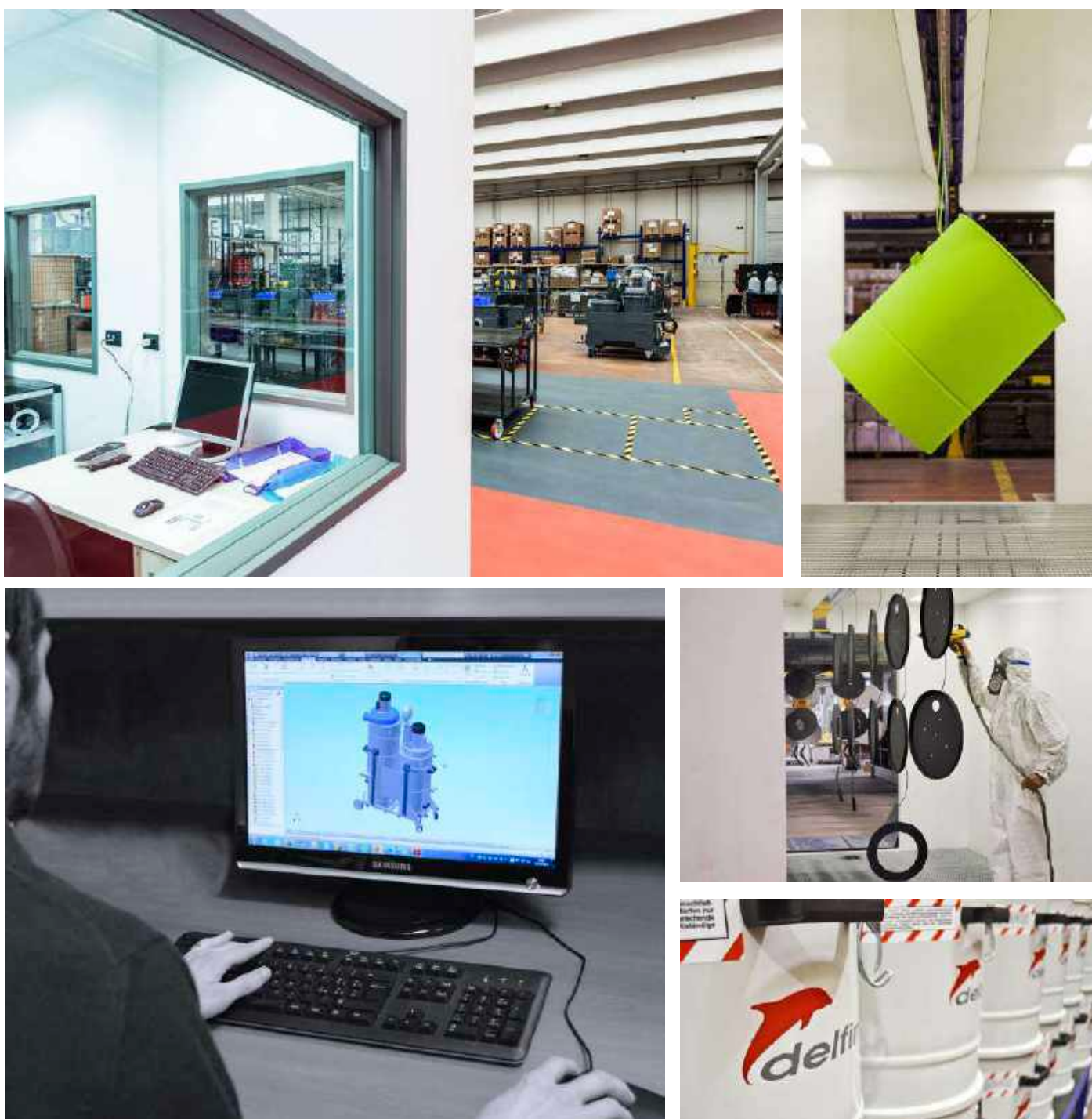

Perchè scegliere una soluzione di aspirazione Delfin? Why should you choose a Delfin vacuum solution?



Tutti i colori del mondo

Grazie alla nostra linea di verniciatura interna, realizzare tutti i colori della gamma RAL nonché qualsiasi colore personalizzato è possibile in tempi rapidissimi!

All the colors in the world

Thanks to our internal powder coating line, to paint in any RAL color as well as any custom color, it is possible in a very short time!



L'automazione che ti serve

I nostri ingegneri sono abituati ad interfacciarsi con i nostri clienti per capire e fornire tutte le risposte e le soluzioni alle esigenze di automazione su macchine e linee di processo.

The automation you need

Our engineers assist our customers directly in order to provide all the answers and solutions to the requests of automation on machinery and process lines.



73

Scelti dai migliori

I nostri aspiratori sono stati scelti negli anni dai migliori costruttori di macchine italiani, tedeschi ed internazionali.

Chosen by the best

Over the years our vacuum units have been chosen by the best italian, german and international OEMs.



La giusta soluzione, sempre!

Come il sistema SPARK TRAP, studiato per abbattere le scintille durante l'aspirazione di materiali incandescenti e proteggere il filtro.

Always the right solution!

For example the SPARK TRAP system which was design in order to deflect and cool down sparks when vacuuming white-hot dust.



Una miriade di risposte tecniche.

Le soluzioni personalizzate Delfin sono studiate sulle tue esigenze e si basano su più di 25 anni di know-how tecnico sviluppato sul campo.

Infinite technical results!

Delfin's customized solutions are designed on your requests, grounded on more than 25 years of know-how and on the field experience.



Non "solo" aspiratori...

Delfin sviluppa ed installa anche sistemi di trasporto pneumatico, studiati e costruiti sulle esigenze del cliente.

Not "only" industrial vacuums...

Delfin designs also pneumatic conveyors which are engineered and built on the specific requirements of the client.



Unità di aspirazione ad alto vuoto High vacuum suction units

Le unità di aspirazione ad alto vuoto della linea Delfin DHV sono il risultato della notevole esperienza accumulata negli anni nei settori applicativi più pesanti e complessi. Possono essere applicati in qualsiasi ambiente ove occorra pulire o trasportare notevoli quantità di materiale polveroso, granulare, liquido e fangoso, accumulabile in contenitori incorporati oppure in separatori inforcabili da 1 o più metri cubi. Ogni DHV è modulare, personalizzato sulle esigenze specifiche del cliente, studiato nei minimi particolari, e può anche prevedere strutture montate su camion o rimorchi di vario genere.

Delfin's DHV high vacuum line is the result of 25 years of know-how in the most difficult application fields. These power monsters can be efficiently used in any industrial environment where it is mandatory to clean or move huge quantities of dusty, granular, liquid or muddy materials. In order to maximize efficiency, DHV units have to be used with appropriate containers or combined with separators of 1 m³ or more. Each DHV is a modular solution, customized on the specific needs of customers and can also be provided as truck or trailer mounted.

74



Qualche Referenza / References (extract)

AUTOMOTIVE

Audi
BMW
Bridgestone
Caterpillar
Citroen
Continental
Dallara Automobili
Delphi
Federal Mogul
Fiat Auto
Fiat Iveco
Ford
General Motors
Honda
Honeywell Turbo Tech.
Jaguar Land Rover
Magneti Marelli
MAZDA
Mercedes-Benz
Michelin
Nissan
Peugeot-Citroen
Pirelli
Renault
Rolls Royce
Suzuki International
Toyota Motor Industries
Valeo
Volkswagen
YAMAHA

ALIMENTARE / FOOD & BEVERAGE

Acqua San benedetto
American Sugar Refining
Cadbury
Carlberg
Coca-Cola
DANISCO
Dr. Oetker
FERRERO
Flacq
Frisian Flag
Heineken
IMPORTACO
Indofood
INTERFLOUR
John Smith
JOWA
La Lorraine
Maestro Swiss Food Medigrain
Molino Alba
Nestlè
Nestlé Purina Pet Care
Olympic Brewery
Pepsico
Pfeifer & Langen
Werk Elsdorf Zuckerfabrik

IND. PESANTE / HEAVY INDUSTRY

3M Company
Arcelor
CBR
Dillinger
General Electric
General Marine
Holcim
Indocement
John Zink
Posco
Sealmaker
Thyssen - Krupp

MATERIE PRIME / RAW MATERIALS

ENI S.P.A.
Eppco
Gas Authority of India
Indian Oil Corporation
Linde Gas
Minera Escondida
Shell Gas

CHIMICO/FARMACEUTICO / CHEMICAL & PHARMA

Abbott Espana
AKZO NOBEL
BASF
Bayer
Bayer Material Science
Bintang Toedjoe
Bristol Meyer Squibbs
Chandra Asri
Chevron Phillips
Dr.Reddy's Laboratories
Essilor India
FMC Inc
Fresenius kabi
Galvanisation Industrielle
Glaxo Smith Kline
HIKMA Giordania
Janssen Pharmaceutical
Kalbe Farma
Kansai Paint
Larex
Laser
Linde Gaz
MERIAL
Millipore
Mylan Laboratories
Novartis
Novartis Consumer
Pfizer Pharmaceutical
Roche Diagnostics
ROCKWOOL
Sanofi Aventis
Schlumberger
Shell Gas
Smelting Indonesia
Sud-Chemie
Takeda Pharma
Winthrop Pharmaceuticals
Xellia Pharmaceuticals
Zimmer Orthopedics
P&G (Procter and Gamble)
Polymer-Chemie
Faber-Castell Cosmetics
SOLVAY

MECCANICA / ENGINEERING

Alstom power
Beghelli
BOSCH
Cartier
Caterpillar
Conttek
H.F.B. Laser Technology
Heco Schrauben
HONEYWELL
Komatsu
LOMBARDINI
Grindwell Morton
Widia
Medartis
Merlo
MICHELIN
Micro Mechanics
Technology
MITSUBA
Phenix Systems
ROLLS ROYCE
SCHAEFFLER
Schumag
Siemens
VEOLIA

AEROSPAZIALE / AEROSPACE

AER LINGUS
Aerostar
AIRBUS
Alenia Aeronautica
ASCO
Boeing
Bombardier
DASSAULT
Eurocopter
Magellan Aerospace
MECACHROME
SAGEM (by SAFRAM)
Sonaca
SR Technics
Techspace Aero
THOMPSON AERO SEATING
Xian Airplane
Manufacturing
Zodiac Aerospace



Delfin Srl
Strada della Merla 49/a
10036 Settimo Torinese - TO - Italy

T. +39 011 800 55 00
F. +39 011 800 55 06
delfin@delfinvacuums.it

www.delfinvacuums.it